

Küchen Kollektion ²⁰¹³

Kitchen Collection · Collection de cuisine

The logo for Kela, featuring the word "kela" in a bold, white, lowercase sans-serif font with a small white star above the letter "a", set against a dark blue square background.

kela⁺

Inhalt

Index · Sommaire

4

Kochserien

Fleischtopf, Bratentopf, Milchtopf, Pfannen oder Bräter. Hochwertige Kochserien in vielen Ausführungen. Die passenden Deckel sind auch einzeln erhältlich.

Cooking equipment

Casseroles, milk saucepans, pans or roasting dishes. High-quality cooking equipment ranges in a variety of designs. The matching lids are also available individually.

Séries de casseroles

Cocottes, faitouts, pots à lait, poêles ou casseroles à fond épais. Séries de grande qualité en différents modèles. Les couvercles appropriés sont également disponibles individuellement.

30

Asiatisch Kochen

Woks mit passendem Zubehör.

Asian cuisine

Woks with matching accessories.

Cuisine asiatique

Woks avec les accessoires correspondants.

32

Auflaufformen

Aus Keramik in verschiedenen Größen und Formen.

Baking pans

Ceramic, in various sizes and shapes.

Moules à soufflé

En céramique, de différentes tailles et différentes formes.

NEW

34

Messer und Scheren

In unterschiedlichen Formen aus verschiedenen Materialien.

Knives, scissors and shears

In various forms and materials.

Couteaux et ciseaux

De différentes formes en différents matériaux.

40

Küchenhelfer

Waagen, Küchenhelfer, Timer oder Streuer. Wir führen ein kompetentes Küchensortiment.

Kitchen accessories

Scales, kitchen accessories, timers or shakers. We offer a comprehensive range of kitchen equipment.

Ustensiles de cuisine

Balances, ustensiles de cuisine, minuteurs ou salières/poivrières. Nous proposons une gamme complète pour la cuisine.

66

Vorratsdosen

Von mini bis maxi, aus Glas oder Acryl.

Storage jars

From mini to maxi, in glass or acrylic.

Boîtes de conservation

Taille mini à maxi, en verre ou acrylique.

70

Besteckserie Siena

Schöne Besteckserie aus Edelstahl 18/10.

Cutlery range Siena

Attractive cutlery range in stainless steel 18/10.

Couverts Siena

Jolis couverts en acier inoxydable 18/10.

72

Kaffee und Tee

Für jedes heiße Getränk hat Kela die passenden Kannen und Gläser.

Coffee and tea

Kela has the perfect pots and glasses for any hot drink.

Café et thé

Pour toutes les boissons chaudes, Kela propose les cafetières/théières et les verres adaptés.

78

Barzubehör

Flaschenverschlüsse, Sektkühler und Cocktail-Shaker.

Bar accessories

Bottle stoppers, sparkling wine coolers and cocktail shakers.

Accessoires pour bar

Bouchons à champagne et à vin, seaux à champagne et shakers.

80

Körbe und Stövchen

Hochwertig verarbeitete Brotkörbe sowie alles aus verchromtem Draht.

Baskets and teapot warmers

Finely crafted bread baskets and everything made from chrome-plated wire.

Corbeilles et chauffe-plats

Corbeilles à pain de grande qualité, existent également en fil chromé.

91

Wohnaccessoires

Schirmständer, Uhren, Gießkannen, Brotkasten oder Trolleys. Hier finden Sie die passenden Wohnaccessoires.

Home accessories

Umbrella stands, clocks, watering cans, bread bins or trolleys. You will find the matching home accessories here.

Accessoires de décoration

Porte-parapluies, horloges, arrosoirs, boîtes à pain ou Trolleys. Vous trouverez ici les accessoires de décoration adaptés.

99

Treteimer

Sehr hochwertige Treteimer für die Küche. Wir liefern auch die passenden Müllbeutel dazu.

Pedal bins

Premium quality pedal bins for the kitchen. We also supply the matching bin liners.

Poubelles à pédale

Poubelles à pédale de grande qualité pour la cuisine. Nous livrons également les sacs correspondants.

110

Körbe

Trendige Farben in unterschiedlichen Ausführungen.

Baskets

The latest colors in a variety of designs.

Corbeilles

Différentes finitions, dans des coloris tendance.

115

Textilien

Küchentextilien und Tisch-Sets für den perfekt gedeckten Tisch.

Textiles

Kitchen textiles and table sets for a perfectly laid table.

Textiles

Textiles pour la cuisine et sets de table pour une table parfaitement dressée.

139

**Appetizer**

Nicht nur für Feinschmecker und Gourmets - unsere neue Appetizerserie.

Appetizer

Not just for foodies and gourmets - our new Appetizer range.

Appetizer

Notre nouvelle collection gourmande Appetizer n'est pas réservée qu'aux gourmets.

146/160

Fondues und Zubehör

Alles rund ums Thema Fondue.

Fondue sets and accessories

Everything you need for the perfect fondue.

Fondues et accessoires

Tout sur le thème de la fondue.

156

Bowlen-Sets

Aus feuerfestem Glas mit passendem Zubehör.

Punch sets

Made from heat-resistant glass with matching accessories.

Sets à Punch/Sangria

En verre résistant au feu avec accessoires correspondants.

170

Wissenswertes

Über weitere Bereiche der Marke Kela. Hier finden Sie auch unsere Allgemeinen Geschäftsbedingungen.

Further information

About other elements of the Kela brand. You will find our General Terms and Conditions here.

Informations utiles

Vous trouverez également plus d'explication sur la marque Kela, ainsi que nos conditions générales de vente.

Edition

> Die sehr hochwertigen Pfannen und Töpfe der Serie Edition sind aus Edelstahl 18/10 in Glanzoptik, mit Kapselboden und 0,8 mm Wandstärke. Das Besondere sind die formschönen, ansatzlosen Hohlgriffe. Alle Töpfe haben einen Glasdeckel mit Edelstahlgriff.

>> The luxurious pots and pans in the Edition range are made from glossy-look stainless steel 18/10, with a cast-iron-clad aluminium base and a wall thickness of 0.8 mm. As a special feature, they have attractively shaped, seamless hollow handles. All pans have a glass lid with a stainless steel handle.

>>> La collection Edition, de très haute qualité se compose de poêles, de casseroles, de faitouts et de marmites en acier inoxydable 18/10 brillant, avec un fond encapsulé d'une épaisseur de 0.8 mm.

Cette collection design se démarque par ses poignées originales qui bénéficient d'un nouveau système de fixation. Tous les faitouts et marmites sont livrés avec un couvercle en verre muni d'une poignée en acier.



Wasserkessel 15 cm Ø 2,0 L

Kettle - Bouilloire

1 - 8

16411 4025457164118

18/10 Edelstahl · Stainless steel · Inox

Glänzend · Bright · Brillant

Edition

Edelstahl 18/10
Stainless steel · Inox

Guarantee
5



0 - 180°



Bratentopf 16 cm Ø 1,5 L

Saucepot · Faitout

1 - 12

16400 4025457164002

Glänzend · Bright · Brillant



Bratentopf 20 cm Ø 2,3 L

Saucepot · Faitout

1 - 6

16402 4025457164026

Glänzend · Bright · Brillant



Bratentopf 24 cm Ø 4,2 L

Saucepot · Faitout

1 - 6

16404 4025457164040

Glänzend · Bright · Brillant



Fleischtopf 16 cm Ø 2,0 L

Covered saucepot · Marmite

1 - 12

16401 4025457164019

Glänzend · Bright · Brillant



Fleischtopf 20 cm Ø 4,2 L

Covered saucepot · Marmite

1 - 6

16403 4025457164033

Glänzend · Bright · Brillant



Fleischtopf 24 cm Ø 5,5 L

Covered saucepot · Marmite

1 - 6

16405 4025457164057

Glänzend · Bright · Brillant



Milchtopf 14 cm Ø 1,8 L

Milk pan · Pot à lait

1 - 12

16397 4025457163975

Glänzend · Bright · Brillant



Stielkasserolle 16 cm Ø 1,5 L

Casserole with handle · Casserole à manche

1 - 12

16398 4025457163982

Glänzend · Bright · Brillant



Stielkasserolle 20 cm Ø 2,6 L

Casserole with handle · Casserole à manche

1 - 6

16399 4025457163999

Glänzend · Bright · Brillant

Edition

Edelstahl 18/10
Stainless steel · Inox

Garantie
5 Jahre



0 - 180°



Spaghettitopf 24 cm Ø 8,0 L

Spaghetti pot · Marmite à Pâtes

1 - 4

16409 4025457164095

18/10 Edelstahl · Stainless steel · Inox

Glänzend · Bright · Brillant



Spargeltopf 16 cm Ø 4,6 L

Asparagus pot · Cuit-Asperges

1 - 6

16408 4025457164088

18/10 Edelstahl · Stainless steel · Inox

Glänzend · Bright · Brillant



Rechteck-Bräter 8,0 L

Rectangular roasting tray

Cocotte à braiser rectangulaire

1 - 3

16410 4025457164101

18/10 Edelstahl · Stainless steel · Inox

Glänzend · Bright · Brillant

Edition

> Die Pfannen der Serie Edition sind mit einer 3-schichtig, keramisch verstärkten, Non-Stick C3⁺-Beschichtung. Hervorragende Antihaftbeständigkeit, hohe Kratzbeständigkeit sowie eine sehr gute Abriebbeständigkeit.

>> The pans in the Edition range have a triple-layer, ceramic-reinforced, non-stick C3⁺ finish. Excellent non-stick properties, extremely scratch- and abrasion-resistant.

>>> Le revêtement des poêles de la collection Edition sont composés de 3 épaisseurs, renforcés par des particules de céramique, non-adhérent C3⁺. Ce revêtement de part sa dureté est anti-adhérent, et il est particulièrement résistant aux rayures et à l'abrasion.



Edelstahl 18/10
Stainless steel · Inox

Garantie
5



0 - 180°

Bratpfanne 20 cm Ø

Frying pan · Poêle

1 - 6

16413 4025457164132

18/10 Edelstahl · Stainless steel · Inox

Glänzend · Bright · Brillant



Bratpfanne 24 cm Ø

Frying pan · Poêle

1 - 6

16406 4025457164064

18/10 Edelstahl · Stainless steel · Inox

Glänzend · Bright · Brillant



Bratpfanne 28 cm Ø

Frying pan · Poêle

1 - 6

16407 4025457164071

18/10 Edelstahl · Stainless steel · Inox

Glänzend · Bright · Brillant



Edition

> Die sehr hochwertigen Töpfe der Serie Edition sind aus Edelstahl 18/10 in Glanzoptik, mit Kapselboden und 0,8 mm Wandstärke. Das Besondere sind die formschönen, ansatzlosen Hohlgriffe. Alle Töpfe haben einen Glasdeckel mit Edelstahlgriff.

>> The luxurious saucepans in the Edition range are made from glossy-look stainless steel 18/10, with a cast-iron-clad aluminium base and a wall thickness of 0.8 mm. As a special feature, they have attractively shaped, seamless hollow handles. All pans have a glass lid with a stainless steel handle.

>>> La collection Edition, de très haute qualité se compose de poêles, de casseroles, de faitouts et de marmites en acier inoxydable 18/10 brillant, avec un fond encapsulé d'une épaisseur de 0.8 mm. Cette collection design se démarque par ses poignées originales qui bénéficient d'un nouveau système de fixation. Tous les faitouts et marmites sont livrés avec un couvercle en verre muni d'une poignée en acier.



Kochtopf-Set

Cooking pot-set

Sets Faitouts-Marmites

16396 4025457163968 1 - 2



4-teilig · 4 pièces · 4 pièces

18/10 Edelstahl · Stainless steel · Inox

Glänzend · Bright · Brillant

Kapselboden · Capsule base · Fond encapsulé

0,8 mm: Wandstärke · Thickness · Epaisseur paroi

4 mm: Glasdeckel · Glass lid · Couvercle en verre

Bratentopf 20 cm Ø, Fleischtopf 16 cm Ø, 20 cm Ø und 24 cm Ø

Saucepot 20 cm Ø, Covered saucepot 16 cm Ø, 20 cm Ø and 24 cm Ø

Faitout 20 cm Ø, Marmite 16 cm Ø, 20 cm Ø et 24 cm Ø

Culina

> Die hochwertigen Töpfe der Serie Culina sind aus Edelstahl 18/10 in Glanzoptik, mit Kapselboden und 0,8 mm Wandstärke. Alle Töpfe haben einen Glasdeckel mit Edelstahlgriff.

>> The luxurious saucepans in the Culina range are made from glossy-look stainless steel 18/10, with a cast-iron-clad aluminium base and a wall thickness of 0.8 mm. All pans have a glass lid with a stainless steel handle.

>>> La collection Culina de très haute qualité en acier inoxydable 18/10 brillant possède un fond encapsulé d'une épaisseur de 0.8 mm. Toutes ces pièces sont livrés avec un couvercle en verre avec poignée en acier.



Kochtopf-Set

Cooking pot-set

Set Faitouts-Casserole

16395 4025457163951 1 - 2 



4-teilig · 4 pieces · 4 pièces

Kapselboden · Capsule base · Fond encapsulé

18/10 Edelstahl · Stainless steel · Inox

Glänzend · Bright · Brillant

0,8 mm: Wandstärke · Thickness · Epaisseur paroi

4 mm: Glasdeckel · Glass lid · Couvercle en verre

Stielkasserolle 16 cm Ø, Bratentopf 20 cm Ø, Fleischtopf 16 cm Ø, 24 cm Ø

Casserole with long handle 16 cm Ø, Saucepot 20 cm Ø, Covered saucepot 16 cm Ø, 24 cm Ø

Casserole à manche 16 cm Ø, Faitout 20 cm Ø, Marmite 16 cm Ø, 24 cm Ø

Cailin

> Die hochwertigen Pfannen und Töpfe der Serie Cailin sind aus Edelstahl 18/10 in Glanzoptik, mit Kapselboden und 0,8 mm Wandstärke. Alle Töpfe haben einen Glasdeckel mit Edelstahlgriff.

>> The luxurious saucepans in the Cailin range are made from glossy-look stainless steel 18/10, with a cast-iron-clad aluminium base and a wall thickness of 0.8 mm. All pans have a glass lid with a stainless steel handle.

>>> La collection Cailin de très haute qualité en acier inoxydable 18/10 brillant possède un fond encapsulé d'une épaisseur de 0.8 mm. Toutes ces pièces sont livrés avec un couvercle en verre avec poignée en acier.



Bratentopf 16 cm Ø 1,5 L
Saucepot · Faitout

1 - 6

10955 4025457109553

Glänzend · Bright · Brillant



Bratentopf 20 cm Ø 3,0 L
Saucepot · Faitout

1 - 4

10956 4025457109560

Glänzend · Bright · Brillant



Bratentopf 24 cm Ø 5,0 L
Saucepot · Faitout

1 - 4

10957 4025457109577

Glänzend · Bright · Brillant



Fleischtopf 16 cm Ø 2,0 L
Covered saucepot · Marmite

1 - 6

10958 4025457109584

Glänzend · Bright · Brillant



Fleischtopf 20 cm Ø 3,5 L
Covered saucepot · Marmite

1 - 4

10959 4025457109591

Glänzend · Bright · Brillant



Fleischtopf 24 cm Ø 6,0 L
Covered saucepot · Marmite

1 - 4

10960 4025457109607

Glänzend · Bright · Brillant

Cailin

Edelstahl 18/10
Stainless steel · Inox

Guarantee
5 years



0 - 180°



Gemüsetopf 24 cm Ø 9,0 L

Stockpot · Marmite

1 - 2

10961 4025457109614

Glänzend · Bright · Brillant



Gemüsetopf 28 cm Ø 13,5 L

Stockpot · Marmite

1 - 2

10962 4025457109621

Glänzend · Bright · Brillant



Fondue-Set

Fondue-set · Service à fondue

1 - 4

10968 4025457109683

10-teilig · 10 pieces · 10 pièces

a 18/10 Edelstahl · Stainless steel · Inox

b Edelstahl · Stainless steel · Inox



Stielkasserolle 16 cm Ø 1,5 L

Casserole with handle · Casserole à manche

1 - 6

10964 4025457109645

Glänzend · Bright · Brillant



Milchtopf 14 cm Ø 1,8 L

Milk pan · Pot à lait

1 - 12

10963 4025457109638

Glänzend · Bright · Brillant



Bratpfanne 24 cm Ø

Frying pan · Poêle

1 - 6

10965 4025457109652

Greblon® Beschichtung
Greblon® coating · Revêtement Greblon®



Bratpfanne 28 cm Ø

Frying pan · Poêle

1 - 4

10966 4025457109669

Greblon® Beschichtung
Greblon® coating · Revêtement Greblon®



Kerros

> Die Aluguss-Serie Kerros ist eine komplette Serie mit Pfannen, Töpfen und Brätern. Diese sind mit einer 3-schichtigen, keramisch verstärkten, Antihft-versiegelung versehen. C3+ ist eine hochwertige 6 Sterne Beschichtung von Weilburger, Germany. Neben der hervorragenden Antihftwirkung zeichnet sich C3+ durch eine hohe Anti-Kratzbeständigkeit und eine sehr gute Abriebbeständigkeit aus.

>> Our Kerros cast aluminium range comprises a full set of pans, saucepans and roasting trays. They come with triple-layer, ceramic-reinforced non-stick coating. C3+ is a high-grade 6-star coating made by Weilburger, Germany. In addition to its excellent non-stick properties, C3+ is also extremely scratch- and abrasion-resistant.

>>> La collection Kerros en fonte alu se compose de poêles, de faitouts et de casseroles. Le revêtement de tous ces articles se compose de trois épaisseurs renforcés par des particules de céramique. Ce revêtement de part sa dureté et ses caractéristiques est anti-adhérent et résiste particulièrement aux rayures et à l'abrasion. Ce revêtement « Weilburger », technologie allemande a été classé C3+,6 étoiles.



Kerros ^{★★★★★★} die komplette 6 Sterne Serie

> Kerros, the complete line with 6 stars

>> Kerros, la collection 6 étoiles



11549



11550



11552



11556



11557



11558



11565



11553



11566



11554



11555



15157



15152



11563



15153



11560



11561



15150



15151



15155



11559



11562



15156



11564

Kerros



0 - 180°



Stielkasserolle 16 cm Ø 1,0 L

Casserole with long handle
Casserole à manche

1 - 6 

11556 4025457115561 

Aluguss · Cast aluminium · Fonte d'aluminium
5 mm



Stielkasserolle 18 cm Ø 1,4 L

Casserole with long handle
Casserole à manche

1 - 6 

11557 4025457115578 

Aluguss · Cast aluminium · Fonte d'aluminium
5 mm



Stielkasserolle 20 cm Ø 1,7 L

Casserole with long handle
Casserole à manche

1 - 6 

11558 4025457115585 

Aluguss · Cast aluminium · Fonte d'aluminium
5 mm



Fleischtopf 16 cm Ø 1,0 L

Covered saucepot · Marmite

1 - 6 

11549 4025457115493 

Aluguss · Cast aluminium · Fonte d'aluminium
5 mm



Fleischtopf 20 cm Ø 1,7 L

Covered saucepot · Marmite

1 - 6 

11550 4025457115509 

Aluguss · Cast aluminium · Fonte d'aluminium
5 mm



Fleischtopf 24 cm Ø 3,2 L

Covered saucepot · Marmite

1 - 6 

11552 4025457115523 

Aluguss · Cast aluminium · Fonte d'aluminium
5 mm

Kerros



0 - 180°



Bratpfanne 18 cm Ø
Frying pan · Poêle

1 - 6

11560 4025457115608 

Aluguss · Cast aluminium · Fonte d'aluminium
5 mm



Bratpfanne 20 cm Ø
Frying pan · Poêle

1 - 6

11561 4025457115615 

Aluguss · Cast aluminium · Fonte d'aluminium
5 mm



Bratpfanne 24 cm Ø
Frying pan · Poêle

1 - 6

15150 4025457151507 

Aluguss · Cast aluminium · Fonte d'aluminium
5 mm



Bratpfanne 28 cm Ø
Frying pan · Poêle

1 - 6

15151 4025457151514 

Aluguss · Cast aluminium · Fonte d'aluminium
5 mm



Servierpfanne 32 cm Ø 5,0 L
Serving pan · Sauteuse

1 - 4 

11554 4025457115547 

Aluguss · Cast aluminium · Fonte d'aluminium
5 mm



Servierpfanne 36 cm Ø 7,0 L
Serving pan · Sauteuse

1 - 4 

11555 4025457115554 

Aluguss · Cast aluminium · Fonte d'aluminium
5 mm



Crêpes-Pfanne 28 cm Ø
Crepe pan · Crêpière

1 - 6

15155 4025457151552 

Aluguss · Cast aluminium · Fonte d'aluminium
5 mm

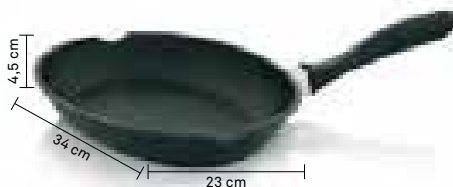

Fischpfanne
Fish pan · Poêle à poisson

1 - 6 

11559 4025457115592 

Aluguss · Cast aluminium · Fonte d'aluminium
5 mm

Kerros





0 - 180°



Topfhalter

Pot holder · Manique

1 - 24 

11566 4025457115660 

2-teilig · 2 pieces · 2 pièces

100 % Baumwolle · Cotton · Coton



Eckpfanne 28 x 28 cm 4,5 L

Square frying pan · Sauteuse carrée

1 - 4 

11565 4025457115653 

Aluguss · Cast aluminium · Fonte d'aluminium
5 mm

Glasdeckel · Glass lid · Couvercle en verre



Servierpfanne 28 x 28 cm 6,0 L

Serving pan · Sauteuse

1 - 4 

11553 4025457115530 

Aluguss · Cast aluminium · Fonte d'aluminium
5 mm

Aromaknopf · Aroma knob · Bouton arôme



Wok 32 cm Ø 4,0 L

Wok · Wok

1 - 6 

15157 4025457151576 

Aluguss · Cast aluminium · Fonte d'aluminium
5 mm

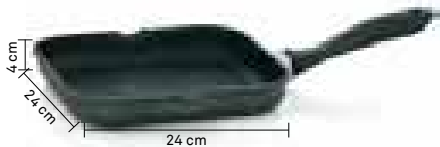

Grill-Pfanne 24 x 24 cm

Griddle pan · Poêle à griller

1 - 6

11562 4025457115622 

Aluguss · Cast aluminium · Fonte d'aluminium
5 mm

2 Ausgüsse · 2 Spouts · 2 Becs verseur

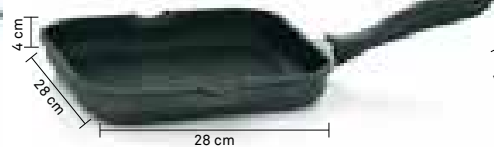

Grill-Eckpfanne 28 x 28 cm

Square griddle pan · Poêle à griller

1 - 6

15156 4025457151569 

Aluguss · Cast aluminium · Fonte d'aluminium
5 mm

2 Ausgüsse · 2 Spouts · 2 Becs verseur

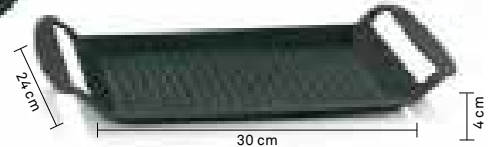

Grill-Platte 30 x 24 cm

Griddle · Poêle à griller

1 - 6 

11564 4025457115646 

Aluguss · Cast aluminium · Fonte d'aluminium
5 mm



Kerros



0 - 180°

Rechteck-Bräter 5,5 L

Rectangular roasting tray
Cocotte à braiser rectangulaire

1 - 4 11512 4025457151521 

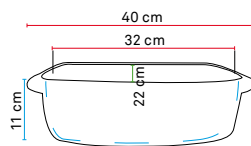

Deckel aus feuerfestem Glas
Lid oven-proof glass
Couvercle avec verre résistant au feu

Aluguss · Cast aluminium · Fonte d'aluminium
6 mm



Rechteck-Bräter 6,5 L

Rectangular roasting tray
Cocotte à braiser rectangulaire

1 - 4 11563 4025457115639 

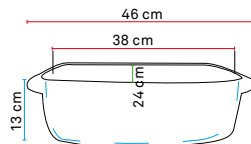

Deckel aus feuerfestem Glas
Lid oven-proof glass
Couvercle avec verre résistant au feu

Aluguss · Cast aluminium · Fonte d'aluminium
5 mm



Oval-Bräter 8,0 L

Oval roasting tray · Cocotte à braiser ovale

1 - 4 11513 4025457151538 

Deckel aus feuerfestem Glas
Lid oven-proof glass
Couvercle avec verre résistant au feu

Aromaknopf · Aroma knob · Bouton arôme

Aluguss · Cast aluminium · Fonte d'aluminium
5 mm

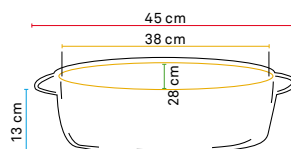

Brasa/Azzurro ★★★★★

> Die Pfannen der Serien Brasa und Azzurro sind aus Aluguss und mit der 3-schichtigen Antihafbeschichtung C3 von Weilburger, Germany, versehen. C3 hat eine sehr gute Antihafwirkung, Anti-Kratzbeständigkeit und Abriebbeständigkeit. Die Pfannen sind für den Induktionsherd geeignet.

>>The pans in the Brasa and Azzurro range are made from cast aluminium and come with C3 triple-layer non-stick coating from Weilburger, Germany. C3 has a highly effective non-stick surface and a scratch- and abrasion-proof finish. The pans are suitable for use on induction cookers.

>>> Les poêles de la collection Brasa et Azzuro sont en fonte alu dont le fond est renforcé par trois épaisseurs. Le revêtement est classé anti-adhérent C3+ . Toutes ces poêles peuvent également être utilisées sur induction.



Brasa/Azzurro ★★★★★



0 - 180°



Bratpfanne Brasa 26 cm Ø
Frying pan · Poêle

1 - 6

11540 4025457115400 Aluguss · Cast aluminium · Fonte d'aluminium
5,5 mm

Bronze · Bronze · Bronze

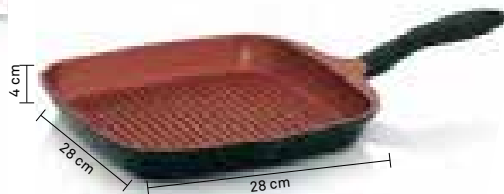

Grill-Pfanne Brasa 28 x 28 cm
Griddle pan · Poêle à griller

1 - 6

11542 4025457115424 Aluguss · Cast aluminium · Fonte d'aluminium
5,5 mm

1 Ausguss · 1 Spout · 1 Pec verseur

Bronze · Bronze · Bronze



Bratpfanne Azzurro 26 cm Ø
Frying pan · Poêle

1 - 6

11541 4025457115417 Aluguss · Cast aluminium · Fonte d'aluminium
5,5 mm

Blau · Blue · Bleu



Grill-Pfanne Azzurro 28 x 28 cm
Griddle pan · Poêle à griller

1 - 6

11543 4025457115431 Aluguss · Cast aluminium · Fonte d'aluminium
5,5 mm

1 Ausguss · 1 Spout · 1 Bec verseur

Blau Blue · Bleu

Kosma

> Eine hochwertige Kochtopf-Serie aus geschmiedetem Aluminium, mit Weilburger C3+ Antihaf-Versiegelung. Außenseite grau eloxiert. Griffe aus Bakelit-Kunststoff.

>> A high-quality range of saucepans made from forged aluminium, with Weilburger C3+ non-stick finish. Exterior grey anodised. Handles made from bakelite plastic.

>>> Une série de casseroles de qualité en aluminium forgé avec revêtement antiadhérent Weilburger C3+. Côté extérieur gris anodisé. Manches en plastique bakélite.

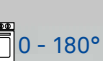

Kosma ☆☆☆☆☆



0 - 180°



Fleischtopf 16 cm Ø 1,5 L
Covered saucepot · Faitout

1 - 4

11572 4025457115721

Aluguss · Cast aluminium · Fonte d'aluminium
4 mm

Geschmiedet · Forged · Forgé



Fleischtopf 20 cm Ø 3,0 L
Covered saucepot · Faitout

1 - 4

11573 4025457115738

Aluguss · Cast aluminium · Fonte d'aluminium
4 mm

Geschmiedet · Forged · Forgé



Fleischtopf 24 cm Ø 5,0 L
Covered saucepot · Faitout

1 - 4

11574 4025457115745

Aluguss · Cast aluminium · Fonte d'aluminium
4 mm

Geschmiedet · Forged · Forgé



Stielkasserolle 16 cm Ø 1,5 L
Casserole with handle · Casserole à manche

1 - 4

11570 4025457115707

Aluguss · Cast aluminium · Fonte d'aluminium
4 mm

Geschmiedet · Forged · Forgé



Stielkasserolle 20 cm Ø 3,0 L
Casserole with handle · Casserole à manche

1 - 4

11571 4025457115714

Aluguss · Cast aluminium · Fonte d'aluminium
4 mm

Geschmiedet · Forged · Forgé



Bratpfanne 20 cm Ø
Frying pan · Poêle

1 - 6

11575 4025457115752

Aluguss · Cast aluminium · Fonte d'aluminium
4 mm

Geschmiedet · Forged · Forgé



Bratpfanne 24 cm Ø
Frying pan · Poêle

1 - 6

11576 4025457115769

Aluguss · Cast aluminium · Fonte d'aluminium
4 mm

Geschmiedet · Forged · Forgé



Bratpfanne 28 cm Ø
Frying pan · Poêle

1 - 6

11577 4025457115776

Aluguss · Cast aluminium · Fonte d'aluminium
4 mm

Geschmiedet · Forged · Forgé

Stoneline®

> **Robuste, harte und kratz feste Antihaftbeschichtung. Gesund und fettfrei braten wie auf Naturstein. Innen und außen leicht zu reinigen. Auch für Induktion geeignet.**

>> **Extreme hard and tough scratch-proof Non-stick coating. Healthy and nonfat frying, like on a natural hot stone. Easy Clean Effect: Inside and outside.**

Suitable even for induction cookers.

>> **Anti-adhérent / Revêtement robuste, très résistant aux éraflures. Poêler sain et sans graisse, comme sur une pierre naturelle. Entretien général très simple - intérieur et extérieur. Adaptée à l'induction.**



Bratpfanne 16 cm Ø
Frying pan · Poêle

1 - 12

16370 4025457163708



Aluminium 4,5 mm



Bratpfanne 20 cm Ø
Frying pan · Poêle

1 - 6

15474 4025457154744



Aluminium 4,5 mm



Bratpfanne 24 cm Ø
Frying pan · Poêle

1 - 6

15475 4025457154751



Aluminium 4,5 mm



Bratpfanne 28 cm Ø
Frying pan · Poêle

1 - 6

15476 4025457154768



Aluminium 4,5 mm



Bratpfanne 24 cm Ø
Frying pan · Poêle

1 - 6

16391 4025457163913



Aluminium 4,5 mm

Mit abnehmbarem Griff
With removable handle
Avec manche amovible



Bratpfanne 28 cm Ø
Frying pan · Poêle

1 - 6

16392 4025457163920



Aluminium 4,5 mm

Mit abnehmbarem Griff
With removable handle
Avec manche amovible

Stoneline®

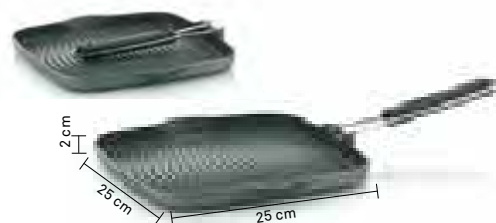

Grill-Pfanne 25 x 25 cm

Griddle pan · Poêle à griller

1 - 12

16377 4025457163777



Aluminium 3 mm

2 Ausgüsse, klappbarer Griff, ohne Induktion
2 Spouts, foldable handle, without induction
2 Becs verseur, manche pliable,
pas sur induction



Grill-Eckpfanne 28 x 28 cm

Square griddle pan · Poêle à griller

1 - 8

16375 4025457163753



Aluminium 4,5 mm

2 Ausgüsse · 2 Spouts · 2 Becs verseur



Swing-up Pfanne

Swing-up pan · Poêle swing

1 - 4

16373 4025457163739



Aluminium 4 mm

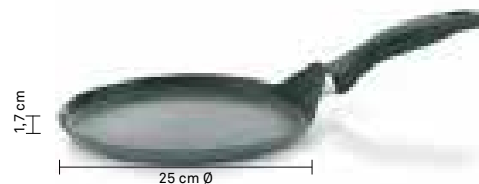

Crêpes-Pfanne

Crêpe pan · Crêpière

1 - 10

16374 4025457163746



Aluminium 3 mm

Stoneline®

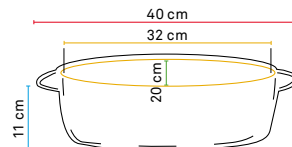
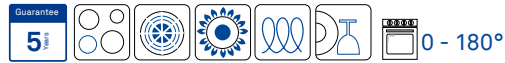

Rechteck-Bräter 5,6 L
Rectangular roasting tray
Cocotte à braiser rectangulaire

1 - 4

15504 4025457155048

Aluguss · Cast aluminium · Fonte d'aluminium
4 mm

Deckel feuerfestes Glas
Lid oven-proof glass
Couvercle verre résistant au feu

0 - 220°

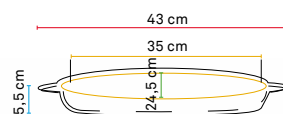
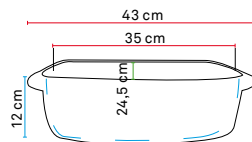

Rechteck-Bräter XXL 7,5 L
Rectangular roasting tray
Cocotte à braiser rectangulaire

1 - 2

16382 4025457163821

Aluguss · Cast aluminium · Fonte d'aluminium
4 mm

0 - 260°



Stoneline®



Servierpfanne 32 cm Ø 3,4 L

Serving pan · Sauteuse

1 - 2

16372 4025457163722

Aluminium 4,5 mm



Eckpfanne 28 x 28 cm 4,2 L

Square frying pan · Sauteuse carrée **16385** 4025457163852 1 - 2

Aluguss · Cast aluminium · Fonte d'aluminium 5 mm

2 Thermogriffschützer · 2 Thermal handle covers · 2 Thermo protection pour les poignées



Stielkasserolle 18 cm Ø 2,2 L

Casserole with long handle
Casserole à manche

1 - 2

16379 4025457163791

Aluminium 4,5 mm



Fleischtopf 20 cm Ø 2,6 L

Covered saucepot · Marmite

1 - 2

16380 4025457163807

Aluminium 4,5 mm



Fleischtopf 24 cm Ø 4,5 L

Covered saucepot · Marmite

1 - 2

16381 4025457163814

Aluminium 4,5 mm



Campana

> Glasdeckel Campana mit Edelstahlrand und Edelstahlknopf.

Hitzebeständig bis 180°. Für Töpfe mit 16 cm Ø, 20 cm Ø, 24 cm Ø und 28 cm Ø.

>> Glass lid Campana with stainless steel rim and stainless steel knob.

Heat-resistant up to 180°. For saucepans 16 cm Ø, 20 cm Ø, 24 cm Ø and 28 cm Ø.

>>> Couvercle en verre avec joint et poignée en acier inoxydable 18/10.

Résistant à la chaleur jusqu'à 180°, Adaptable aux contenants de Ø 16-20-24 et 28 cm.

Edelstahl 18/10
Stainless steel · Inox



0 - 180°



Glasdeckel 16 cm Ø

Glass lid · Couvercle en verre

1 - 16

10874 4025457108747



Flach · Flat · Plat



Glasdeckel 20 cm Ø

Glass lid · Couvercle en verre

1 - 16

10875 4025457108754



Flach · Flat · Plat



Glasdeckel 24 cm Ø

Glass lid · Couvercle en verre

1 - 8

10876 4025457108761



Hoch · High · Cloche



Glasdeckel 28 cm Ø

Glass lid · Couvercle en verre

1 - 8

10877 4025457108778



Hoch · High · Cloche



Pfannen Glasdeckel 24 cm Ø

Glass lid · Couvercle en verre

1 - 12

10997 4025457109973



Extra hoch · Extra high · Cloche

Pyrex-Glas



Pfannen Glasdeckel 28 cm Ø

Glass lid · Couvercle en verre

1 - 10

10998 4025457109980



Extra hoch · Extra high · Cloche

Pyrex-Glas

Callisto

> Glasdeckel Callisto mit Edelstahlrand und Bakelitknopf.

Hitzebeständig bis 180°. Für Töpfe mit 16 cm Ø, 20 cm Ø, 24 cm Ø und 28 cm Ø.

>> Glass lid Callisto with stainless steel rim and bakelite knob.

Heat-resistant up to 180°. For saucepans 16 cm Ø, 20 cm Ø, 24 cm Ø and 28 cm Ø.

>>> Couvercle en verre avec joint en acier inoxydable 18/10 et poignée en bakelit.

Résistant à la chaleur jusqu'à 180°; Adaptable aux contenants de Ø 16-20-24 et 28 cm.



Glasdeckel 16 cm Ø

Glass lid · Couvercle en verre

1 - 16

10870 4025457108709



Flach · Flat · Plat



Glasdeckel 20 cm Ø

Glass lid · Couvercle en verre

1 - 16

10871 4025457108716



Flach · Flat · Plat



Glasdeckel 24 cm Ø

Glass lid · Couvercle en verre

1 - 8

10872 4025457108723



Hoch · High · Cloche



Glasdeckel 28 cm Ø

Glass lid · Couvercle en verre

1 - 8

10873 4025457108730



Hoch · High · Cloche



Pfannen-Glasdeckel 24 cm Ø

Glass lid · Couvercle en verre

1 - 12

10995 4025457109959



Extra hoch · Extra high · Cloche

Pyrex-Glas



Pfannen-Glasdeckel 28 cm Ø

Glass lid · Couvercle en verre

1 - 10

10996 4025457109966



Extra hoch · Extra high · Cloche

Pyrex-Glas

Zubehör



Pfannenschutz-Set Amparo

Pan protection set

Protection intercalaire pour poêles

- 12* 24

10720 4025457107207



Filz · Felt · Feutre

3-teilig · 3 pieces · 3 pièces

39 cm



29 cm Ø

Spritzschutz

Splash guard · Grille anti-éclaboussures

1 24 72

17116 4025457171161



Drahtgeflecht · Wire netting · Grille métallique

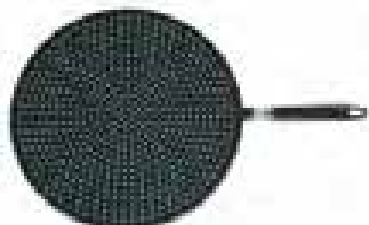

33 cm Ø

Spritzschutz Carlina

Splash guard · Grille anti-éclaboussures

1 10 40

10847 4025457108471



Silikon · Silicone · Silicone



5 cm Ø

Edelstahl 18/10

Stainless steel · Inox

Fleischthermometer Punkto

Meat thermometer · Thermomètre à viande

1 12 144

15315 4025457153150



18/10 Edelstahl · Stainless steel · Inox

0 - 120 °

Flötenkessel

18/10 Edelstahl · Stainless steel · Inox



Edelstahl 18/10
Stainless steel · Inox

Wasserkessel Flauta 2,5 L

Kettle · Bouilloire

1 - 6

16955 4025457169557

18/10 Edelstahl · Stainless steel · Inox : 0,6 mm

Glänzend · Bright · Brillant

Induktionsboden

Bottom induction · Avec fond induction

Rutschfester Griff

Nonslip handle · Manche anti-dérapant



Edelstahl 18/10
Stainless steel · Inox

Wasserkessel Pito 3,0 L

Kettle · Bouilloire

1 - 6

16956 4025457169564

18/10 Edelstahl · Stainless steel · Inox : 0,5 mm

Kapselboden, rutschfester Griff

Cast-iron-clad aluminum base, nonslip handle

Fond encapsulé, manche anti-dérapant

Rot · Red · Rouge



Edelstahl 18/10
Stainless steel · Inox

Wasserkessel Pito 3,0 L

Kettle · Bouilloire

1 - 6

16957 4025457169571

18/10 Edelstahl · Stainless steel · Inox : 0,5 mm

Kapselboden, rutschfester Griff

Cast-iron-clad aluminum base, nonslip handle

Fond encapsulé, manche anti-dérapant

Schwarz · Black · Noir



Edelstahl 18/10
Stainless steel · Inox

Wasserkessel Pito 3,0 L

Kettle · Bouilloire

1 - 6

16958 4025457169588

18/10 Edelstahl · Stainless steel · Inox : 0,5 mm

Kapselboden, rutschfester Griff

Cast-iron-clad aluminum base, nonslip handle

Fond encapsulé, manche anti-dérapant

Weiß · White · Blanc

Wok-Set

> Kochen mit dem Wok ist nährstoffschonend und das Gemüse bleibt knackig. Die schwere gusseiserne Pfanne ist geeignet für Gas, Ceran und E-Herd.
 >> Cooking in a wok preserves nutrients, and vegetables remain crisp. This heavy cast iron pan is suitable for use on gas, Ceran and electric cookers.
 >>> La cuisson Wok permet de garder saveur et vitamines. La fonte est utilisable tous feux sauf induction.



15157



16 Seite · Page · Page



Wok-Set Mini 24 cm Ø

Wok-set · Set Wok

1 - 4

77747 4025457777479

5-teilig · 5 pieces · 5 pièces

- a Gusseisen · Cast iron · Fonte
- b Glas · Glass · Verre
- c Edelstahl · Stainless steel · Inox
- d Bambus · Bamboo · Bambou



Wok-Set Asia 36 cm Ø

Wok-set · Set Wok

1 - 2

77943 4025457779435

5-teilig · 5 pieces · 5 pièces

- a Gusseisen · Cast iron · Fonte
- b Metall · Metal · Métal
- c Edelstahl · Stainless steel · Inox
- d Bambus · Bamboo · Bambou

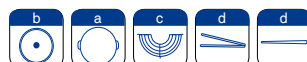

Wok-Set Cosmo 36 cm Ø

Wok-set · Set Wok

1 - 2

66452 4025457664526

5-teilig · 5 pieces · 5 pièces

- a Gusseisen · Cast iron · Fonte
- b Glas · Glass · Verre
- c Edelstahl · Stainless steel · Inox
- d Bambus · Bamboo · Bambou

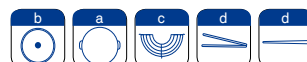

Wok-Zubehör



Siebe Tamis

Colander · Passoires mini

1 - 60

77924 4025457779244

4 Stück · 4 pieces · 4 pièces

18/10 Edelstahl · Stainless steel · Inox



Rechaud Hot

Rechaud · Réchaud

1 - 4

60170 4025457601705

3-teilig · 3 pieces · 3 pièces

Metall verchromt · Metal chromed · Métal chromé

Gasbrenner, besonders geeignet für Woks
Gas burner, especially for woks
Brûleur gaz, idéal pour wok



Gasbrenner Hot

Gas burner · Brûleur gaz

1 6 24

63040 4025457630408

18/10 Edelstahl · Stainless steel · Inox

Nachfüllbar · Refillable · Rechargeable

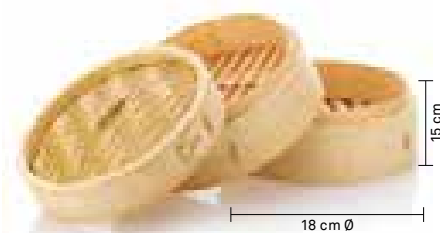

Dämpf-Set Vital

Steamer-Set · Cuit vapeur

1 - 18

77160 4025457771606

Bambus · Bamboo · Bambou

3-teilig · 3 pieces · 3 pièces

2x Dampfkörbchen, 1x Deckel
2x Steamer baskets, 1x Lid
2x Corbeilles, 1x Couvercle

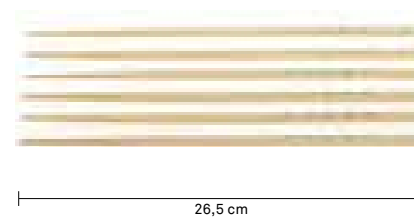

Chopsticks Asia

Chopsticks · Chopsticks

1 - 100

77905 4025457779053

Bambus · Bamboo · Bambou

10 Paar · 10 Pairs · 10 Paires

Maleen

Porzellan · Porcelain · Porcelaine



Handwritten signature



Perfekt Servieren

Ofenzange Maria

Oven tongs · Pince à four

1 6 60 

10826 4025457108266 

18/10 Edelstahl · Stainless steel · Inox



Edelstahl 18/10
Stainless steel · Inox



CE issued by
DVGW, Germany

DIN EN ISO 9994

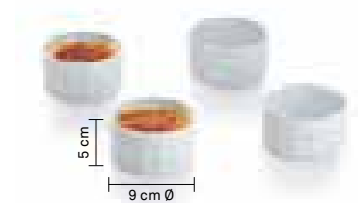

Schälchen-Set Maleen

Crème brûlée dishes · Ramequins

1 - 12 

10750 4025457107504 

Porzellan · Porcelain · Porcelaine

4-teilig · 4 pieces · 4 pièces

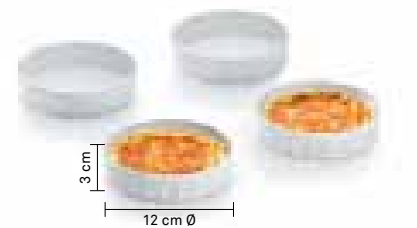

Schälchen-Set Maleen

Crème brûlée dishes · Coupelles crème brûlée

1 - 12 

10751 4025457107511 

Porzellan · Porcelain · Porcelaine

4-teilig · 4 pieces · 4 pièces

Gourmet-Gasbrenner Manou

Gourmet gas burner · Gourmet brûleur gaz

1 - 20 

10947 4025457109478 

Metall · Metal · Métal

Flamme regulierbar
Flame adjustment · Ajustable flamme



Auflaufform Maleen

Casserole dish · Plat à four

1 - 16 

10732 4025457107320 

Porzellan · Porcelain · Porcelaine



Auflaufform Maleen

Casserole dish · Plat à four

1 - 10 

10731 4025457107313 

Porzellan · Porcelain · Porcelaine

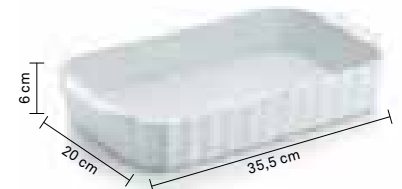

Auflaufform Maleen

Casserole dish · Plat à four

1 - 6 

10730 4025457107306 

Porzellan · Porcelain · Porcelaine



Auflaufform Maleen

Casserole dish · Plat à four oval

1 - 16 

10735 4025457107351 

Porzellan · Porcelain · Porcelaine



Auflaufform Maleen

Casserole dish · Plat à four oval

1 - 10 

10734 4025457107344 

Porzellan · Porcelain · Porcelaine



Auflaufform Maleen

Casserole dish · Plat à four oval

1 - 8 

10733 4025457107337 

Porzellan · Porcelain · Porcelaine

Ceramics

> Keramik, ultrascharfe Klinge,
geruchs- und geschmacksneutral,
ABS-Komfort-Griff, leicht und handlich
» Ceramic, ultra-sharp blade, odour-neutral,
ABS comfort handle, lightweight and handy
»» Céramique, lame ultra tranchante ne laisse,
aucune odeur, poignée confort ABS,
haute protection, léger et maniable



Ceramics

Keramik · Ceramics · Céramique

Griff ABS Kunststoff · Handle ABS-Plastic · Poignée ABS-Plastique

Chefmesser 6"

Chef knife · Couteau chef

15749 4025457157493 1 12 48 



Fleischmesser 5"

Carving knife · Couteau viande

15748 4025457157486 1 12 48 



Küchenmesser 3"

Kitchen knife · Couteau d'office

15747 4025457157479 1 12 48 



Santokumesser

Santoku knife · Couteau Santoku

10805 4025457108051 1 12 48 

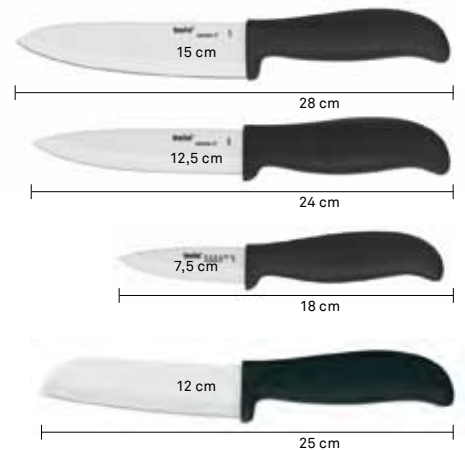

Keramik · Ceramics · Céramique

Griff ABS Kunststoff · Handle ABS-Plastic · Poignée ABS-Plastique

Chefmesser 6"

Chef knife · Couteau chef

15752 4025457157523 1 12 48 



Fleischmesser 5"

Carving knife · Couteau viande

15751 4025457157516 1 12 48 



Küchenmesser 3"

Kitchen knife · Couteau d'office

15750 4025457157509 1 12 48 



Santokumesser

Santoku knife · Couteau Santoku

10806 4025457108068 1 12 48 



Messerschärfer Ming

Sharpening · Fusil à aiguiser

15753 4025457157530 1 8 32 



Keramik · Ceramics · Céramique

Griff PP-Kunststoff · Handle PP-Plastic · Poignée PP-Plastique



Sparschäler Kaito

Potato peeler · Rasoir à légumes

15784 4025457157844 1 12 96 



Keramik · Ceramics · Céramique

Griff ABS-Kunststoff · Handle ABS-Plastic · Poignée ABS-Plastique



Darkato



> Die Antihaftbeschichtung verhindert Ankleben und Korrosion. Die Karbonstahlklinge ist härter und dünner als normaler Stahl und somit besonders scharf. Die Sicherheitshülle schützt und hält die Klinge scharf.

>> The non-stick coating prevents food from sticking and corrosion. The carbon steel blade is harder and thinner than a normal blade, and ultra-sharp. The safety sheath protects the blade and keeps it sharp.

>>> Le revêtement spécial évite que les lames ne collent, ainsi que la corrosion. Le coupant en carbone plus dur et plus fin que la normale favorise une meilleure coupe.

Messer-Set

Knifeset - Set couteau

15986 4025457159862 - - 12*



Karbonstahl · Carbon steel · Acier carbone

Griff PP-Kunststoff · Handle PP-Plastic · Poignée PP-Plastique

3-teilig · 3 pieces · 3 pièces

Fleischmesser · Ausbeinmesser · Küchenmesser

Carving knife · Boning knife · Kitchen knife

Couteau viande · Couteau à désosser · Couteau d'office

Schwarz · Black · Noir



Karbonstahl · Carbon steel · Acier carbone

Griff PP-Kunststoff · Handle PP-Plastic · Poignée PP-Plastique

Fleischmesser 8"

Carving knife · Couteau viande

10840 4025457108402 1 12 72



Brotmesser 8"

Bread knife · Couteau Pain

10841 4025457108419 1 12 72



Santokumesser

Santoku knife · Couteau Santoku

10842 4025457108426 1 12 48



Santokumesser

Santoku knife · Couteau Santoku

10843 4025457108433 1 12 60



Ausbeinmesser 4,5"

Boning knife · Couteau à dessoser

10844 4025457108440 1 12 72



Küchenmesser 3"

Kitchen knife · Couteau d'office

10845 4025457108457 1 12 72



Colorato

› Die Antihaftbeschichtung verhindert Ankleben und Korrosion. Die Karbonstahlklinge ist härter und dünner als normaler Stahl und somit besonders scharf. Die Sicherheitshülle schützt und hält die Klinge scharf.

›› The non-stick coating prevents food from sticking and corrosion. The carbon steel blade is harder and thinner than a normal blade and ultra-sharp. The safety sheath protects the blade and keeps it sharp.

››› Le revêtement spécial évite que les lames ne collent, ainsi que la corrosion. Le coupant en carbone plus dur et plus fin que la normale favorise une meilleure coupe.

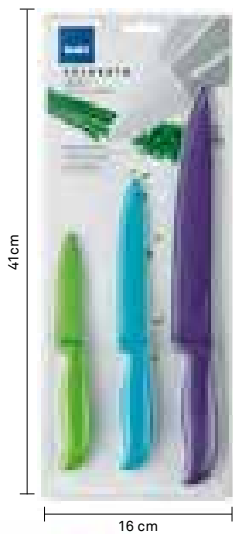

Messer-Set

Knife-set · Set couteau

- - 12*

15983 4025457159831

Karbonstahl · Carbon steel · Acier carbone

Griff PP-Kunststoff · Handle PP-Plastic ·
Poignée PP-Plastique

3-teilig · 3 pieces · 3 pièces

Grün, Türkis, Brombeer
Green, Turquoise, Blackberry
Vert, Turquoise, Mûre



Display Universalschere

Display scissor · Display ciseaux universel

1 - 2

(EPr.)

15984 4025457159848

Karbonstahl · Carbon steel · Acier carbone

Griff PP-Kunststoff · Handle PP-Plastic ·
Poignée PP-Plastique

18-teilig · 18 pieces · 18 pièces

6x Brombeer, Grün, Türkis,
6x Blackberry, Green, Turquoise,
6x Mûre, Vert, Turquoise



Display Küchenmesser

Display kitchen knife
Display couteau d'office

1 - 2

(EPr.)

15982 4025457159824

Karbonstahl · Carbon steel · Acier carbone

Griff PP-Kunststoff · Handle PP-Plastic ·
Poignée PP-Plastique

18-teilig · 18 pieces · 18 pièces

6x Brombeer, Grün, Türkis,
6x Blackberry, Green, Turquoise,
6x Mûre, Vert, Turquoise



Display Ausbeinmesser 5"

Display boning knife
Display couteau à désosser

1 - 2

(EPr.)

15981 4025457159817

Karbonstahl · Carbon steel · Acier carbone

Griff PP-Kunststoff · Handle PP-Plastic ·
Poignée PP-Plastique

18-teilig · 18 pieces · 18 pièces

6x Brombeer, Grün, Türkis,
6x Blackberry, Green, Turquoise,
6x Mûre, Vert, Turquoise



Display Fleischmesser 8"

Display carving knife
Display couteau viande

1 - 2

(EPr.)

15980 4025457159800

Karbonstahl · Carbon steel · Acier carbone

Griff PP-Kunststoff · Handle PP-Plastic ·
Poignée PP-Plastique

18-teilig · 18 pieces · 18 pièces

6x Brombeer, Grün, Türkis,
6x Blackberry, Green, Turquoise,
6x Mûre, Vert, Turquoise

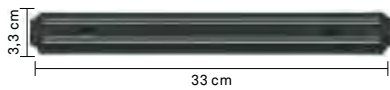

Magnetleiste Flex

Magnetic knife rack · Support mural magnétique

1 12 48

15497 4025457154973

PP-Kunststoff schwarz
PP-Plastic black · PP-Plastique noir

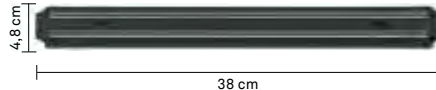

Magnetleiste Flex

Magnetic knife rack · Support mural magnétique

1 12 48

15496 4025457154966

PP-Kunststoff schwarz
PP-Plastic black · PP-Plastique noir

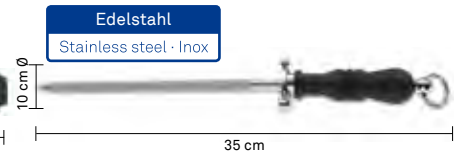

Wetzstahl Darius

Sharpening steel · Fusil

1 12 72

15473 4025457154737

Edelstahl · Stainless steel · Inox
PP-Kunststoff · PP-Plastic · PP-Plastique

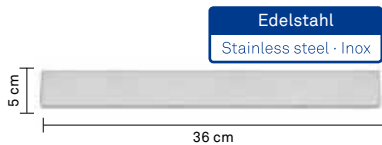

Magnetleiste Plan

Magnetic knife rack · Support mural magnétique

1 6 12

15715 4025457157158

Edelstahl · Stainless steel · Inox

Matt · Matt · Mat

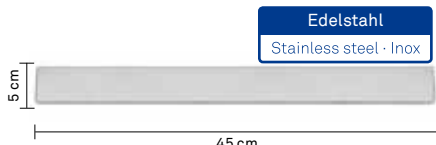

Magnetleiste Plan

Magnetic knife rack · Support mural magnétique

1 6 12

15716 4025457157165

Edelstahl · Stainless steel · Inox

Matt · Matt · Mat



Edelstahl
Stainless steel · Inox

Universalschere 8"

Scissor · Ciseaux universel

1 12 72

15366 4025457153662

Edelstahl · Stainless steel · Inox

ABS-Kunststoff · ABS-Plastic · ABS-Plastique



Edelstahl
Stainless steel · Inox

Geflügelschere Boca 10"

Poultry shears · Ciseaux volaille

1 12 36

15365 4025457153655

Edelstahl · Stainless steel · Inox

POM Griff · Handle POM · Poignée POM

Feststellbar · Lockable · Système de blocage



Edelstahl
Stainless steel · Inox

Geflügelschere Boca 9"

Poultry shears · Ciseaux volaille

1 12 36

15364 4025457153648

Edelstahl · Stainless steel · Inox

PP-Kunststoff · PP-Plastic · PP-Plastique

Feststellbar · Lockable · Système de blocage

Messerserien

Edelstahl · Stainless steel · Inox

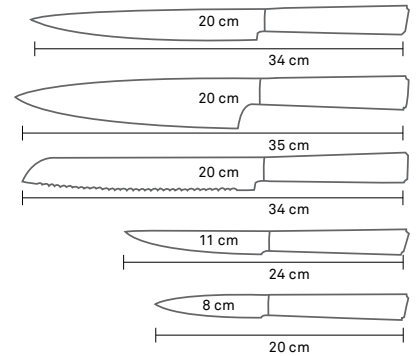

Serie Bistro

Series Bistro · Série Bistro

Edelstahlgriff · Stainless steel handle · Poignée inox

Fleischmesser 8"

Carving knife · Couteau viande

15470 4025457154706 1 12 48



Chefmesser 8"

Chef knife · Couteau chef

15468 4025457154683 1 12 48



Brotmesser 8"

Bread knife · Couteau pain

15469 4025457154690 1 12 72



Ausbeinmesser 4,5"

Boning knife · Couteau à dessoser

15471 4025457154713 1 12 96



Küchenmesser 3"

Kitchen knife · Couteau d'office

15472 4025457154720 1 12 120



Serie Basic

Series Basic · Série Basic

POM Griff · POM Handle · Poignée POM

Fleischmesser 8"

Carving knife · Couteau viande

15352 4025457153525 1 12 72



Chefmesser 8"

Chef knife · Couteau chef

15350 4025457153501 1 12 48



Brotmesser 8"

Bread knife · Couteau pain

15351 4025457153518 1 12 72



Ausbeinmesser 4,5"

Boning knife · Couteau à dessoser

15353 4025457153532 1 12 120



Küchenmesser 3"

Kitchen knife · Couteau d'office

15354 4025457153549 1 12 120



Serie Cuisine

Series Cuisine · Série Cuisine

POM Griff · POM Handle · Poignée POM

Fleischmesser 8"

Carving knife · Couteau viande

15357 4025457153570 1 12 72



Chefmesser 8"

Chef knife · Couteau chef

15355 4025457153556 1 12 48



Brotmesser 8"

Bread knife · Couteau pain

15356 4025457153563 1 12 72



Ausbeinmesser 4,5"

Boning knife · Couteau à dessoser

15358 4025457153587 1 12 120



Küchenmesser 3"

Kitchen knife · Couteau d'office

15359 4025457153594 1 12 120



Rondo

> Sehr hochwertige 18/10 Edelstahl Serie
 >> Very high-quality 18/10 stainless steel series
 >>> Collection haut de gamme 18/10 inox

Edelstahl 18/10
 Stainless steel · Inox

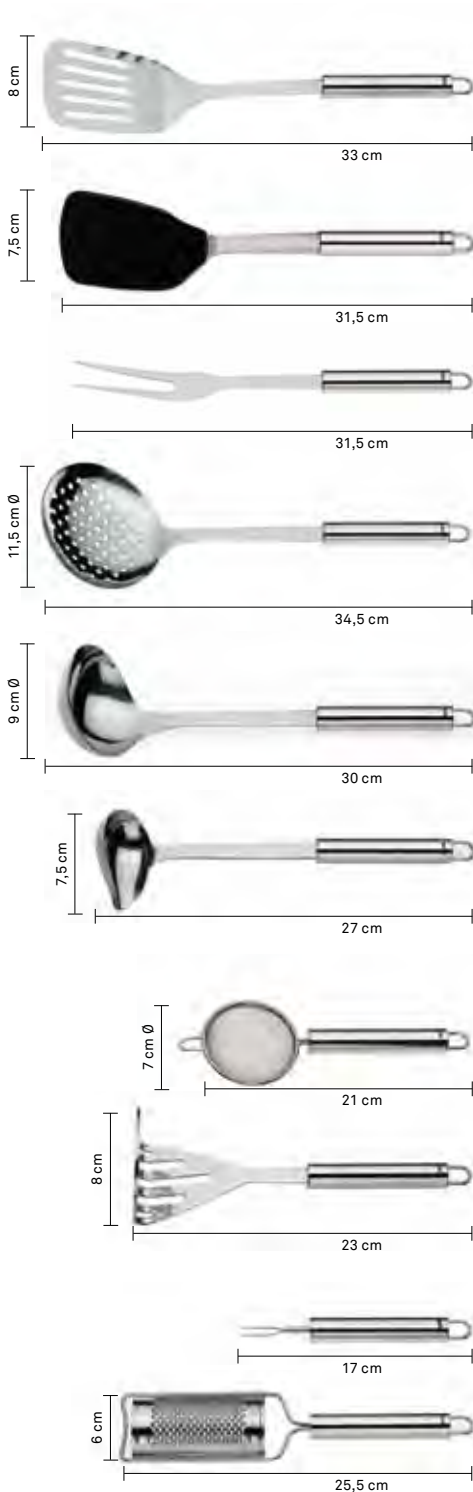

Bratenheber

Spatula · Spatule ajourée

19003 4025457190032 1 12 72



Bratenwender

Spatula · Spatule plate

15930 4025457159305 1 12 72



Silikon · Silicone · Silicone

Fleischgabel

Carving fork · Fourchette de viande

19004 4025457190049 1 12 72



Schaumlöffel

Skimmer · Mousseur

19005 4025457190056 1 12 72



Suppenschöpfer

Soup ladle · Louche

19001 4025457190018 1 12 72



Saucenlöffel

Gravy ladle · Cuillère à sauce

19002 4025457190025 1 12 72



Kaffeeseib

Coffee strainer · Passoire café

19017 4025457190179 1 12 144



Kartoffelstampfer

Potato masher · Ecrase pomme de terre

19006 4025457190063 1 12 72



Pellkartoffelgabel

Potato fork · Pique pomme de terre

19011 4025457190117 1 12 144



Gewürzreibe

Spice grater · Râpe épices

19010 4025457190100 1 12 144



Rondo

Edelstahl 18/10
Stainless steel · Inox



Servierlöffel Serving spoon · Cuillère à service	19007 4025457190070	1	12	72	
Servierlöffel Serving spoon · Cuillère à légumes	19008 4025457190087	1	12	72	
Spaghettilöffel Spaghetti spoon · Cuillère à spaghetti	19061 4025457190612	1	12	72	
Schneebeesen Egg whisk · Fouet	19020 4025457190209	1	12	96	
Schneebeesen Egg whisk · Fouet	19027 4025457190278	1	12	120	
Schneebeesen Egg whisk · Fouet	19019 4025457190193	1	12	144	
Mini-Schneebeesen Mini-egg whisk · Mini fouet	19024 4025457190247	1	24	288	
Schneebeesen Egg whisk · Fouet	19028 4025457190285	1	10	150	
Universalformer Fruitballer · Cuillère boules melon	15325 4025457153259	1	12	144	
Butterformer Butter curler · Coquilleur à beurre	15322 4025457153228	1	12	144	
Sparschäler Y-Form Potato peeler · Rasoir à légumes forme Y	19038 4025457190384	1	12	144	
Sparschäler Potato peeler · Eplucheur	19009 4025457190094	1	12	216	
Sparschäler Potato peeler · Rasoir pomme de terre	19039 4025457190391	1	12	144	
Apfelausstecher Apple corer · Vide pomme	19012 4025457190124	1	12	144	

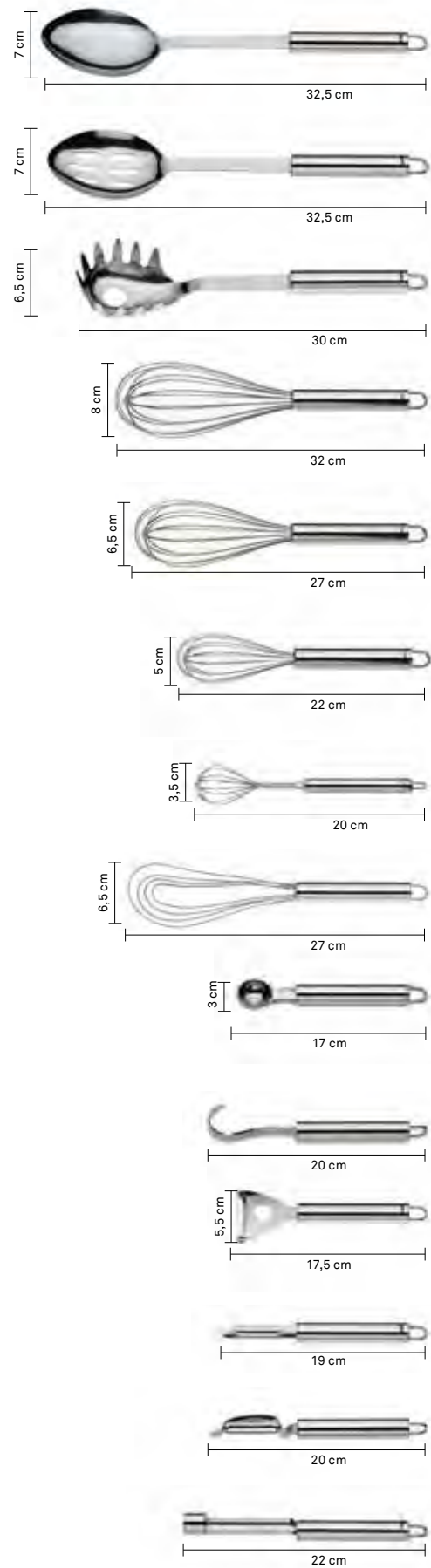

Rondo

Edelstahl 18/10

Stainless steel · Inox



> Sehr hochwertige 18/10 Edelstahl Serie

>> Very high-quality 18/10 stainless steel series

>>> Collection haut de gamme 18/10 inox

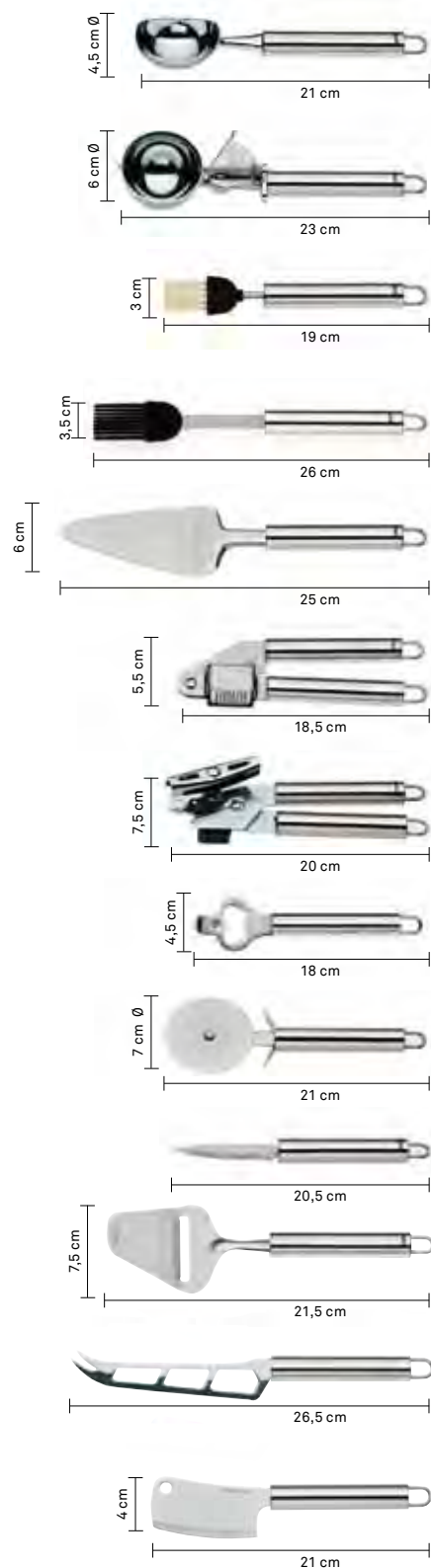
**Eiscremelöffel**

Ice cream scoop · Cuillère à glace

19022 4025457190223 1 12 96**Eisportionierer**

Ice cream scoop · Cuillère à glace

19135 4025457191350 1 12 72**Kuchenpinsel**

Kitchen brush · Pinceau de cuisine

19136 4025457191367 1 12 144**Kuchenpinsel**

Kitchen brush · Pinceau de cuisine

15931 4025457159312 1 12 144

Silikon · Silicone · Silicone

Tortenheber

Cake slicer · Pelle à tarte

19016 4025457190162 1 12 144**Knoblauchpresse**

Garlic press · Presse-ail

19015 4025457190155 1 12 60**Dosenöffner**

Can opener · Ouvre-boîte

19000 4025457190001 1 12 48**Kapselheber**

Bottle opener · Ouvre bouteille

19018 4025457190186 1 12 144**Pizzaschneider**

Pizza cutter · Roulette à pizza

19013 4025457190131 1 12 72**Küchenmesser**

Kitchen knife · Couteau d'office

19026 4025457190261 1 24 240**Käseschneider**

Cheese cutter · Eminceur fromage

19029 4025457190292 1 12 144**Käsemesser**

Cheese knife · Couteau à fromage

15326 4025457153266 1 12 120**Käsebeil**

Cheese cleaver · Hachette à fromage

15327 4025457153273 1 12 120

Rondo

Edelstahl 18/10
Stainless steel · Inox



Teigrad

Pastry wheel · Roulette à pâte **19014** 4025457190148 1 12 144

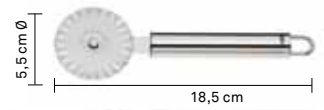

Pasta-Ausstecher

Pasta cutter · Pâte emporte pièce **15323** 4025457153235 1 12 144

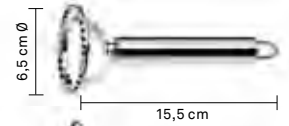

Ravioli-Ausstecher

Ravioli cutter · Raviolis emporte pièce **15324** 4025457153242 1 12 144

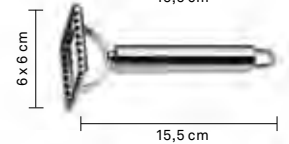

Pizzamesser

Spatula for pizza · Pelle coupante **19138** 4025457191381 1 12 72



Winkelpalette

Icing spatula · Spatule coudée **19139** 4025457191398 1 12 72



Kuchenpalette

Icing spatula · Spatule plate **19140** 4025457191404 1 12 72



Hängeleiste

Hook bar · Barre de suspension **19021** 4025457190216 1 12 60

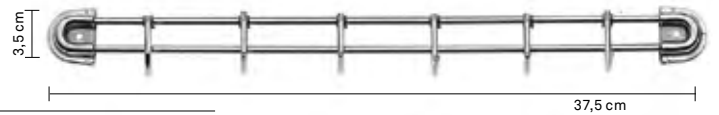

6 Haken · 6 Hooks · 6 Crochets



Gourmet

Silikon 260° hitzebeständig, Griff: Edelstahl 18/10
Silicone fireproofed up to 260°, handle: Stainless steel 18/10
Silicone résistant 260°, poignée: Inox 18/8

Edelstahl 18/10
Stainless steel · Inox

260°
Silikon · Silicone



Gourmet

Edelstahl 18/10

Stainless steel · Inox

260°

Silikon · Silicone



Schneebeesen

Egg whisk · Fouet plat

16268 4025457162688 1 6 72

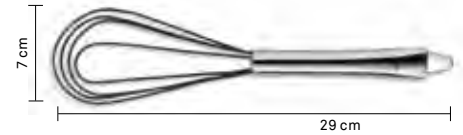

Schneebeesen

Egg whisk · Fouet

16267 4025457162671 1 6 72



Bratenwender

Spatula · Spatule plate

16249 4025457162497 1 6 72



Haushaltszange

Household pliers · Pince de cuisine

16269 4025457162695 1 6 72



Kochlöffel

Cook spoon · Cuillère

16252 4025457162527 1 6 72



Teigschaber

Dough scraper · Spatule à pâte

16244 4025457162442 1 6 72



Teigschaber

Dough scraper · Spatule cul de poule

16227 4025457162275 1 24 144

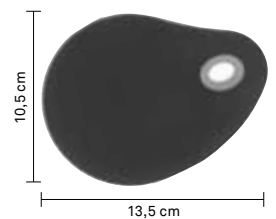

Teigroller

Rolling pin · Rouleau à pâtisserie

16265 4025457162657 1 6 12



Backpinsel

Baking brush · Pinceau plat

16228 4025457162282 1 6 72



Backpinsel

Baking brush · Pinceau rond

16229 4025457162299 1 6 72



Gourmet

Silikon 260° hitzebeständig, Griff: Edelstahl 18/10
 Silicone fireproofed up to 260°, handle: Stainless steel 18/10
 Silicone résistant 260°, poignée: Inox 18/8

Edelstahl 18/10 Stainless steel · Inox	260° Silikon · Silicone	
---	----------------------------	---



Display Teigschaber

Display dough scraper
 Display spatule cul de poule

1 - 4 (EPr.)

15959 4025457159596 

12-teilig · 12 pieces · 12 pièces

4x Brombeer, Grün, Türkis
 4x Blackberry, Green, Turquoise
 4x Mûre, Vert, Turquoise



Display Bratenheber

Display spatula · Display spatule

1 - 4 (EPr.)

15956 4025457159565 

12-teilig · 12 pieces · 12 pièces

4x Brombeer, Grün, Türkis
 4x Blackberry, Green, Turquoise
 4x Mûre, Vert, Turquoise



Display Schneebesen

Display egg whisk · Display fouet

1 - 4 (EPr.)

15957 4025457159572 

12-teilig · 12 pieces · 12 pièces

4x Brombeer, Grün, Türkis
 4x Blackberry, Green, Turquoise
 4x Mûre, Vert, Turquoise



Display Backpinsel

Display baking brush · Display pinceau

1 - 4 (EPr.)

15958 4025457159589 

12-teilig · 12 pieces · 12 pièces

4x Brombeer, Grün, Türkis
 4x Blackberry, Green, Turquoise
 4x Mûre, Vert, Turquoise

Displays



Display-Nussknacker Milano
Display nutcracker · Display casse noix

1 - 4 (EPr.)

15444 4025457154447



Zinkdruckguss
Zinc diecasting · Zinc-moulage sous pression

Gummierte Griffe
Non-slip handle · Manches non glissants

12-teilig · 12 pieces · 12 pièces



Display Dosenöffner Parsa
Display can opener · Display ouvre-bûite

1 - 4 (EPr.)

10827 4025457108273



Edelstahl · Stainless steel · Inox

Griff-Kunststoff
Handle-Plastic · Poignée-Plastique

12-teilig · 12 pieces · 12 pièces

4x Weiß, Grau, Schwarz
4x White, Grey, Black
4x Blanc, Gris, Noir



Display-Sparschâler Ceramics
Display potato peeler
Display rasoir à légumes

1 - 6 (EPr.)

15780 4025457157806



Keramik · Ceramics · Céramique

ABS-Griff · ABS-Handle · Poignée ABS

18-teilig · 18 pieces · 18 pièces

6x Schwarz, Weiß, Rot
6x Black, White, Red
6x Noir, Blanc, Rouge



Display-Sparschâler Ceramics
Display potato peeler
Display rasoir à légumes

1 - 6 (EPr.)

15783 4025457157837



Keramik · Ceramics · Céramique

ABS-Griff · ABS-Handle · Poignée ABS

18-teilig · 18 pieces · 18 pièces

6x Brombeer, Grün, Türkis
6x Blackberry, Green, Turquoise
6x Mûre, Vert, Turquoise



Filosa

Edelstahl · Stainless steel · Inox



91091

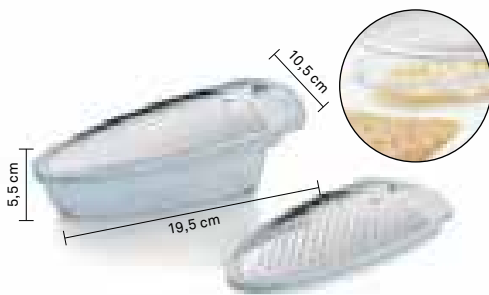

Reibe mit Behälter
Grater with box · Râpe avec contenant

1 6 48

15763 4025457157639

Kunststoff · Plastic · Plastique

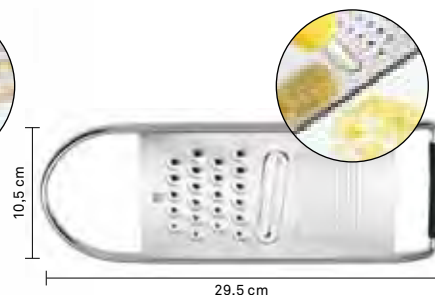

Universalhobel
Universal slicer · Râpe universelle

1 12 72

15758 4025457157585



Gurkenhobel
Cucumber slicer · Râpe à concombres

1 12 72

15755 4025457157554



Swingreibe 2-fach
Swing grater 2 sides · Râpe swing 2 faces

1 6 12

15764 4025457157646

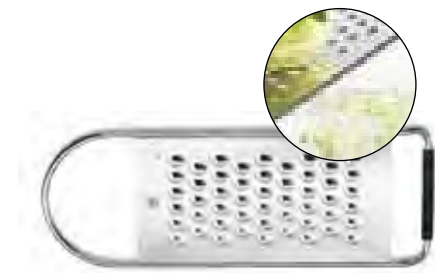

Gemüsereibe
Vegetable slicer · Râpe à légumes

1 12 72

15756 4025457157561

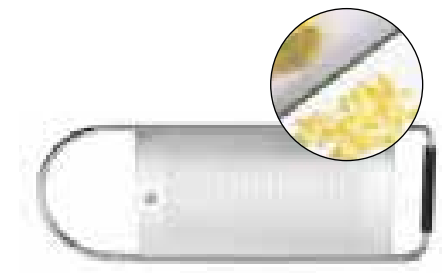

Kartoffelreibe
Potato slicer · Râpe pomme de terre

1 12 72

15757 4025457157578

Filosa

Edelstahl
Stainless steel · Inox

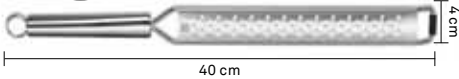
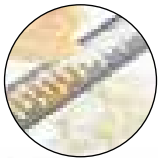

Zestenreibe grob
Zester coarse · Râpe gros trous

1 12 48

15760 4025457157608



Gewürzreibe
Spice grater · Râpe à épices

1 12 48

15761 4025457157615

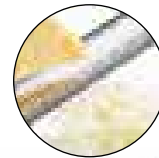

Zestenreibe grob/fein
Zester coarse/fine · Râpe gros/fin

1 12 48

15762 4025457157622

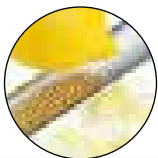

Zestenreibe fein
Zester fine · Râpe fine

1 12 48

10790 4025457107900



Raspel
Grater · Râpe à julienne

1 12 48

10791 4025457107917

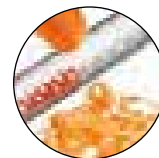

Zestenreibe mittel
Zester medium · Râpe moyenne

1 12 48

10792 4025457107924

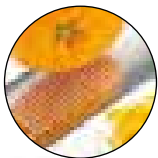

Zestenreibe fein
Zester fine · Râpe fine

1 12 48

10793 4025457107931



Zestenreibe grob
Zester coarse · Râpe

1 12 48

10794 4025457107948



Raspel
Grater · Râpe à lamelles

1 12 48

10795 4025457107955

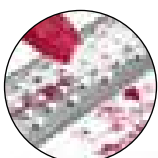

Raspel grob
Grater coarse · Râpe gros grains

1 12 48

10796 4025457107962



Raspel fein
Grater fine · Râpe grains moyen

1 12 48

10797 4025457107979

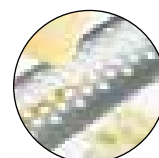

Kronenreibe fein
Grater fine · Râpe grains moyen

1 12 48

10798 4025457107986



Küchenhelfer

Edelstahl · Stainless steel · Inox

Edelstahl
Stainless steel · Inox



4-Kant-Reibe Profi

Quadrangular grater · Râpe 4 faces

1 12 72

19065 4025457190650



Edelstahl · Stainless steel · Inox

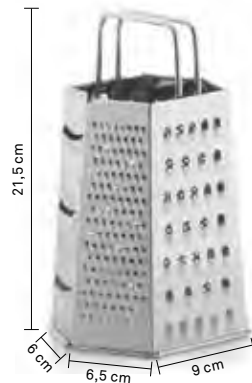

6-Kant-Reibe Profi

Hexagonal grater · Râpe 6 faces

1 6 48

19064 4025457190643



Edelstahl · Stainless steel · Inox



Multireibe Profi

Multi-purpose grater · Râpe multi fonction

1 6 36

19093 4025457190933



Edelstahl · Stainless steel · Inox



Edelstahl 18/10
Stainless steel · Inox

Panier-Set Estrada

Coating set · Set à paner

1 - 16

10846 4025457108464



Edelstahl · Stainless steel · Inox

Glänzend · Bright · Brillant

3-teilig · 3 pieces · 3 pièces



Edelstahl
Stainless steel · Inox

Mörser mit Stößel Gourmet

Mortar with pestle · Mortier avec pilon

1 6 12

16271 4025457162718



Porzellan · Porcelain · Porcelaine

Edelstahl · Stainless steel · Inox

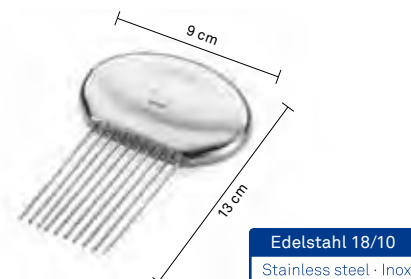

Edelstahl 18/10
Stainless steel · Inox

Zwiebelhalter Malika

Onion holder · Pique oignons

1 12 72

10825 4025457108259



18/10 Edelstahl · Stainless steel · Inox

Profi

18/10 Edelstahl · Stainless steel · Inox

Edelstahl 18/10

Stainless steel · Inox

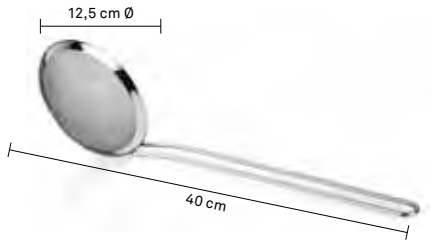

Schaumlöffel
Skimmer · Passoire

1 12 96

19059 4025457190599

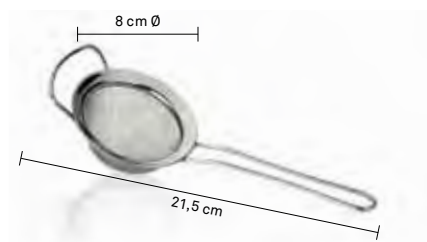

Kaffeiesieb
Coffee colander · Passoire à café

1 10 100

19054 4025457190544

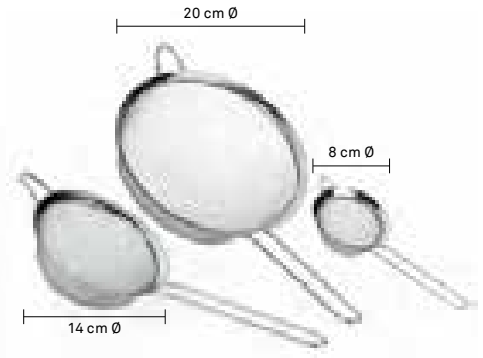

Küchensieb-Set
Colander set · Set passoire cuisine

1 - 8

11074 4025457110740



3 Stück · 3 pieces · 3 pièces

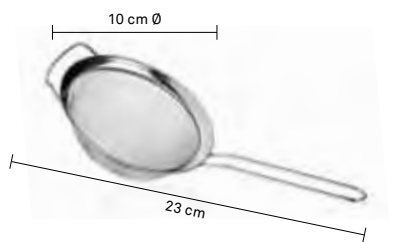

Küchensieb
Colander · Passoire cuisine

1 10 100

19055 4025457190551

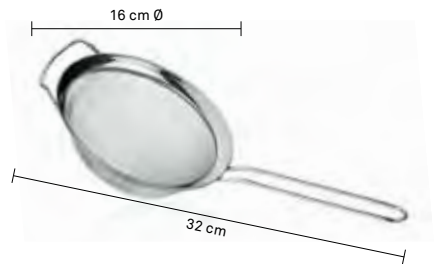

Küchensieb
Colander · Passoire cuisine

1 6 72

19056 4025457190568

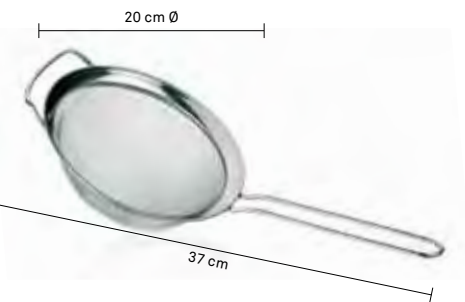

Küchensieb
Colander · Passoire cuisine

1 6 36

19058 4025457190582

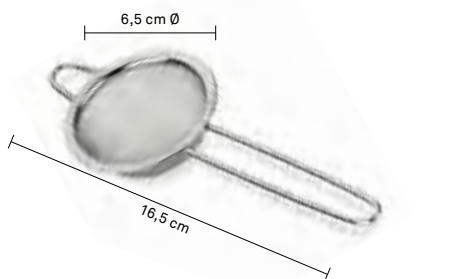

Teesieb
Tea colander · Passoire thé

1 12 360

19053 4025457190537



Tee-/Gewürzzange
Tea and spice tongs · Pince thé/épices

1 12 288 4,5 cm Ø, 15 cm

19050 4025457190506



1 12 288 6 cm Ø, 15 cm

19043 4025457190438



Tee-/Gewürzkugel
Tea and spice ball · Boule thé/épices

1 12 576 5 cm Ø

19051 4025457190513



1 12 288 6 cm Ø

19052 4025457190520





Edelstahl 18/10
Stainless steel · Inox

14-24 cm Ø

Gemüsedämpfer Rosi

Vegetable steamer · Cuit vapeur

1 12 72

19099 4025457190995

18/10 Edelstahl · Stainless steel · Inox

Faltbar · Foldable · Pliable

Für Töpfe von · Suitable for pots of · Ajustable
14 - 24 cm Ø



Edelstahl 18/10
Stainless steel · Inox

22,5 cm

Spaghettizange Fresh

Spaghetti tongs · Pince spaghetti

1 12 72

19123 4025457191237

18/10 Edelstahl · Stainless steel · Inox



Edelstahl 18/10
Stainless steel · Inox

23 cm

Salatzange Fresh

Salad tongs · Pince salade

1 12 72

19124 4025457191244

18/10 Edelstahl · Stainless steel · Inox



Edelstahl 18/10
Stainless steel · Inox

6,5 cm
11 cm
30,5 cm

Spätzleshobel Emma

"Spaetzle" planer high grade
Mandoline à spaetzle

1 - 12

19087 4025457190872

18/10 Edelstahl · Stainless steel · Inox

Stabile Rahmenausführung für kurze Spätzle
Stable framework execution for short Spaetzle
Cadre de qualité pour "Spaetzle" court



Edelstahl
Stainless steel · Inox

11 cm
13,5 cm

Wiegemesser Ganda

Chopping knife · Hachoir

1 - 50

10866 4025457108662

Edelstahl · Stainless steel · Inox



Edelstahl
Stainless steel · Inox

12 cm
17 cm

Wiegemesser Ganda

Chopping knife · Hachoir

1 - 24

10867 4025457108679

Edelstahl · Stainless steel · Inox

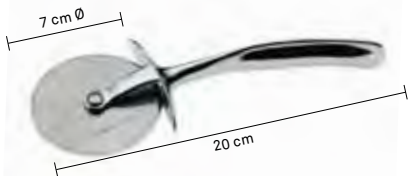

Pizzaschneider Napoli

Pizza cutter · Roulette à pizza

1 12 48

19186 4025457191862

Zinkdruckguss, verchromt
Zinc diecasting, chromed
Zinc-moulage sous pression, chromé

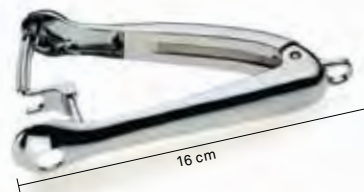

Kirschkerner Napoli

Corer/Stoner · Dénoyauteur cerise

1 12 48

19132 4025457191329

Zinkdruckguss, verchromt
Zinc diecasting, chromed
Zinc-moulage sous pression, chromé

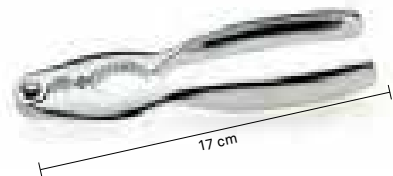

Nussknacker Napoli

Nutcracker · Casse noix

1 12 48

19119 4025457191190

Zinkdruckguss, verchromt
Zinc diecasting, chromed
Zinc-moulage sous pression, chromé



Backen

18/10 Edelstahl · Stainless steel · Inox

Edelstahl 18/10
Stainless steel · Inox

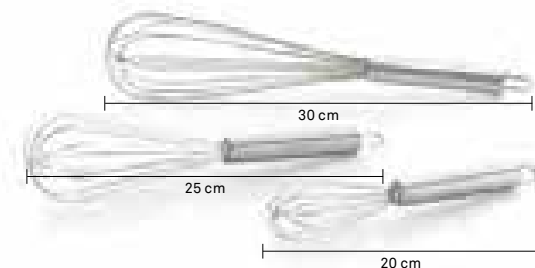

Schneebeesen-Set Senta
Egg whisk set · Set fouets

1 - 48

17908 4025457179082

18/10 Edelstahl · Stainless steel · Inox

3-teilig · 3 pieces · 3 pièces



Abdeckhaube Cara
Cover · Couvre plat

1 - 24

40079 4025457400797

18/10 Edelstahl · Stainless steel · Inox



Netzstreuer Rika
Mesh dredger · Saupoudreuse crépine

1 - 36

19170 4025457191701

18/10 Edelstahl · Stainless steel · Inox

Kunststoffdeckel
Plastic cover · Couvercle plastifié



Feinstreuer Dora
Fine meshed dredger · Saupoudreuse fin

1 - 36

19171 4025457191718

18/10 Edelstahl · Stainless steel · Inox

Kunststoffdeckel
Plastic cover · Couvercle plastifié



Mehlsieb Frieda
Flour sifter · Tamis

1 6 60

19045 4025457190452

18/10 Edelstahl · Stainless steel · Inox



Messkanne Jana 1,0 L
Measuring jug · Mesureur

1 - 12

21055 4025457210556

Kunststoff · Plastic · Plastique



Tortenplatte Tia
Cake plate · Plat à tarte

1 - 8

17932 4025457179327

18/10 Edelstahl · Stainless steel · Inox

Acrylglas · Acrylic · Acrylique



Edelstahl
Stainless steel · Inox

Küchentimer Scura
Kitchen timer · Minuteur

1 10 100

11531 4025457115318

Edelstahl · Stainless steel · Inox

Silikon · Silicone · Silicone

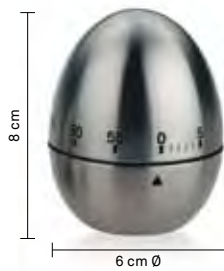

Edelstahl
Stainless steel · Inox

Küchentimer Stone
Kitchen timer · Minuteur

1 10 100

15313 4025457153136

Edelstahl · Stainless steel · Inox



Edelstahl
Stainless steel · Inox

Küchentimer Trafo
Kitchen timer · Minuteur

1 10 100

15312 4025457153129

Edelstahl · Stainless steel · Inox



Edelstahl
Stainless steel · Inox

Küchentimer Cone
Kitchen timer · Minuteur

1 10 100

15311 4025457153112

Edelstahl · Stainless steel · Inox



Küchentimer Kitchen
Kitchen timer · Minuteur

1 12 144

19379 4025457193798

Kunststoff verchromt · Plastic chromed ·
Plastique chromé

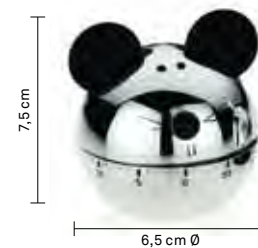

Küchentimer Mouse
Kitchen timer · Minuteur

1 12 144

19381 4025457193811

Kunststoff verchromt · Plastic chromed ·
Plastique chromé

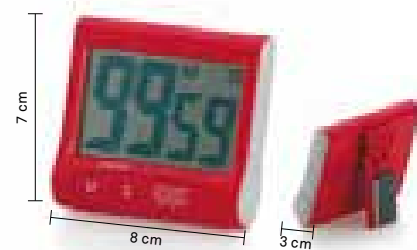

Küchentimer Tempus
Kitchen timer · Minuteur

1 10 100

10803 4025457108037

ABS-Kunststoff, Magnetisch, zum Legen,
Stellen und Anclippen

ABS-Plastic, magnetic, to lay down,
free standing and to clip for

ABS-Plastique, magnétique, à coucher,
à poser et à cliper

Batterie 1x AAA, nicht enthalten
Battery 1x AAA, not included
Pile 1x AAA, non fournie

Rot · Red · Rouge



Küchentimer Tempus
Kitchen timer · Minuteur

1 10 100

10802 4025457108020

ABS-Kunststoff, Magnetisch, zum Legen,
Stellen und Anclippen

ABS-Plastic, magnetic, to lay down,
free standing and to clip for

ABS-Plastique, magnétique, à coucher,
à poser et à cliper

Batterie 1x AAA, nicht enthalten
Battery 1x AAA, not included
Pile 1x AAA, non fournie

Schwarz · Black · Noir



Küchentimer Tempus
Kitchen timer · Minuteur

1 10 100

10800 4025457108006

ABS-Kunststoff, Magnetisch, zum Legen,
Stellen und Anclippen

ABS-Plastic, magnetic, to lay down,
free standing and to clip for

ABS-Plastique, magnétique, à coucher,
à poser et à cliper

Batterie 1x AAA, nicht enthalten
Battery 1x AAA, not included
Pile 1x AAA, non fournie

Weiß · White · Blanc

Anrichten

18/10 Edelstahl · Stainless steel · Inox

Edelstahl 18/10
Stainless steel · Inox

Dessertringe Decore

Dessert rings · Emporte-pièces

1 10 50 

10785 4025457107856 

18/10 Edelstahl · Stainless steel · Inox

Glänzend · Bright · Brillant

3-teilig · 3 pieces · 3 pièces



Dessertringe Decore

Dessert rings · Emporte-pièces

1 6 60 

10780 4025457107801 

18/10 Edelstahl · Stainless steel · Inox

Glänzend · Bright · Brillant

3-teilig · 3 pieces · 3 pièces



Dessertringe Decore

Dessert rings · Emporte-pièces

1 10 50 

10781 4025457107818 

18/10 Edelstahl · Stainless steel · Inox

Glänzend · Bright · Brillant

3-teilig · 3 pieces · 3 pièces



Dessertringe Decore

Dessert rings · Emporte-pièces

1 6 30 

10782 4025457107825 

18/10 Edelstahl · Stainless steel · Inox

Glänzend · Bright · Brillant

3-teilig · 3 pieces · 3 pièces



Dessertringe Decore

Dessert rings · Emporte-pièces

1 6 60 

10784 4025457107849 

18/10 Edelstahl · Stainless steel · Inox

Glänzend · Bright · Brillant

3-teilig · 3 pieces · 3 pièces



Dessertringe Decore

Dessert rings · Emporte-pièces

1 6 60 

10783 4025457107832 

18/10 Edelstahl · Stainless steel · Inox

Glänzend · Bright · Brillant

3-teilig · 3 pieces · 3 pièces



Portionsförmchen Malinda

Portion cups · Mini-coupelles

1 6 48 

10824 4025457108242 

18/10 Edelstahl · Stainless steel · Inox

Matt · Matt · Mat

4-teilig · 4 pieces · 4 pièces



Edelstahl
Stainless steel · Inox

Gewürzgläser Fidelis

Glass jar · Saupoudreuses à épices

1 - 6

10859 4025457108594

Glas · Glass · Verre

Edelstahl · Stainless steel · Inox

6-teilig · 6 pieces · 6 pièces



Edelstahl 18/10
Stainless steel · Inox

Butterdose Fresh

Butter dish · Beurrier

1 - 23

17930 4025457179303

18/10 Edelstahl · Stainless steel · Inox

Acrylglas · Acrylic · Acrylique

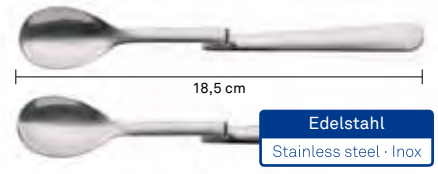

Edelstahl
Stainless steel · Inox

Löffel-Set Fresco

Spoon set · Set-cuillères

1 12 108

28200 4025457282003

Zum Einhängen · For hanging · A suspendre

Edelstahl · Stainless steel · Inox

4 Stück · 4 pieces · 4 pièces



Edelstahl
Stainless steel · Inox

Zuckerdosierer Mirte

Sugar dispenser · Sucrier

1 8 32

10856 4025457108563

Glas · Glass · Verre

Edelstahl · Stainless steel · Inox



Edelstahl
Stainless steel · Inox

Zuckerdosierer Verre 250 ml

Sugar dispenser · Sucrier

- 6* 36

19391 4025457193910

Glas · Glass · Verre

Edelstahl · Stainless steel · Inox



Edelstahl
Stainless steel · Inox

Salz-/Pfefferstreuer Verre

Salt and pepper dredger · Salière-poivrière

- 12* 120

49874 4025457498749

Glas · Glass · Verre

Edelstahl · Stainless steel · Inox



Edelstahl
Stainless steel · Inox

Salz-/Pfefferstreuer Mirte

Salt and pepper dredger · Salière-poivrière

1 6 48

10855 4025457108556

Edelstahl · Stainless steel · Inox

Glas · Glass · Verre

2-teilig · 2 pieces · 2 pièces



Edelstahl
Stainless steel · Inox

Salz-/Pfefferstreuer Twin

Salt and pepper dredger · Salière-poivrière

1 - 48

16921 4025457169212

Edelstahl · Stainless steel · Inox

Matt · Matt · Mat

2-teilig · 2 pieces · 2 pièces



Edelstahl
Stainless steel · Inox

Salz-/Pfefferstreuer Mensa

Salt and pepper dredger · Salière-poivrière

1 - 48

10865 4025457108655

Edelstahl · Stainless steel · Inox

Matt · Matt · Mat

2-teilig · 2 pieces · 2 pièces

Vision

18/10 Edelstahl · Stainless steel · Inox

Edelstahl 18/10

Stainless steel · Inox



Ei-Pick

Egg pick · Pic à oeuf

1 12 240

19245 4025457192456

18/10 Edelstahl · Stainless steel · Inox



Eierbecher-Set

Egg cups · Coquetiers

1 12 72

19246 4025457192463

18/10 Edelstahl · Stainless steel · Inox

4 Stück · 4 pieces · 4 pièces



Eierschneider

Egg slicer · Trancheur à oeuf

1 12 72

19092 4025457190926

18/10 Edelstahl · Stainless steel · Inox



Zitronenpresse

Lemon squeezer · Presse-citron

1 6 36

19200 4025457192005

18/10 Edelstahl · Stainless steel · Inox



Zitronenpresse

Lemon squeezer · Presse-citron

1 - 24

16907 4025457169076

18/10 Edelstahl · Stainless steel · Inox



Butterdose

Butter dish · Beurrier

1 6 60

19243 4025457192432

18/10 Edelstahl · Stainless steel · Inox



Teeei

Tea egg-shaped · Boule à thé

1 12 144

15314 4025457153143

18/10 Edelstahl · Stainless steel · Inox

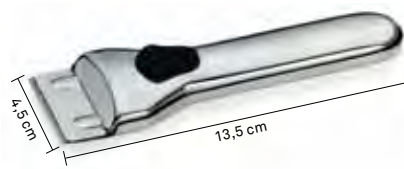

Kochfeldreiniger

Ceran hob cleaner
Grattoir à plaques vitro céramique

1 12 144

19248 4025457192487

18/10 Edelstahl · Stainless steel · Inox

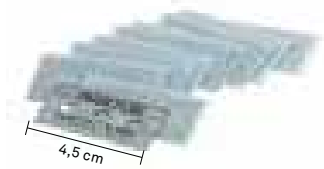

Ersatzklingen-Set

Replacement blades · Lames de remplacement

1 1001000

22001 4002632905261

Metall · Metal · Métal

10 Stück · 10 pieces · 10 pièces

Schüsseln

Edelstahl · Stainless steel · Inox

Edelstahl
Stainless steel · Inox



Rührschüssel Lavina 4 L

Bowl · Jatte

1 4 12

15920 4025457159206



Boden: Silikon · Bottom: Silicone
Sol: Silicone



Küchenschüssel Viso 1,1 L

Bowl · Jatte

1 12 48

19300 4025457193002



Küchenschüssel Viso 1,5 L

Bowl · Jatte

1 12 48

19301 4025457193019



Küchenschüssel Viso 1,8 L

Bowl · Jatte

1 8 32

19302 4025457193026



Küchenschüssel Viso 2,6 L

Bowl · Jatte

1 8 32

19303 4025457193033



Küchenschüssel Viso 3,1 L

Bowl · Jatte

1 6 24

19304 4025457193040



Küchenschüssel Viso 4,5 L

Bowl · Jatte

1 6 24

19305 4025457193057



Küchenschüssel Viso 7,0 L

Bowl · Jatte

1 6 12

19306 4025457193064



Siebe

18/10 Edelstahl · Stainless steel · Inox

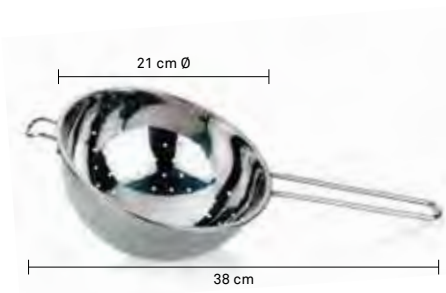

Stielseiher Dalina
Strainer with handle · Passoire avec manche

1 4 24

19090 4025457190902



Salatseiher Dalina
Salad strainer · Passoire salade

1 4 24

19091 4025457190919



Edelstahl 18/10
Stainless steel · Inox



Salatseiher Naira
Salad strainer · Passoire salade

1 6 12

11112 4025457111129



Edelstahl 18/10
Stainless steel · Inox



Salatseiher Naira
Salad strainer · Passoire salade

1 8 16

11113 4025457111136



Edelstahl 18/10
Stainless steel · Inox



Küchensieb Cara
Mesh colander · Passoire cuisine

1 6 48

10880 4025457108808



Küchensieb Cara
Mesh colander · Passoire cuisine

1 6 48

10881 4025457108815



Edelstahl 18/10
Stainless steel · Inox



Küchensieb Cara
Mesh colander · Passoire cuisine

1 6 48

10882 4025457108822



Edelstahl 18/10
Stainless steel · Inox



Löffelablage Cuchara

Spoon holder · Repose cuillère

1 - 18

16945 4025457169458

Porzellan · Porcelain · Porcelaine



Löffelablage Panel

Spoon holder · Repose cuillère

1 - 24

16950 4025457169502

2x Holzlöffel · Wooden spoons · Cuillères en bois

Keramik, Metall verchromt
Ceramic, metal chromed
Céramique, métal chromé



Löffelablage Butler

Spoon holder · Repose cuillère

1 - 18

17906 4025457179068

Holzlöffel · Wooden spoon · Cuillère en bois

Keramik, Metall verchromt
Ceramic, metal chromed
Céramique, métal chromé



Öl-Dosierer Torino 220 ml

Oil dispenser · Huilier

1 - 24

17900 4025457179006

Acryl · Acrylic · Acrylique



Essig-Sprüher Torino 220 ml

Vinegar sprayer · Spray vinaigre

1 - 24

17901 4025457179013

Acryl · Acrylic · Acrylique

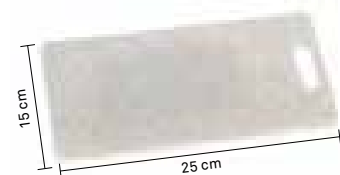

Schneidebrett Graphit

Chopping board · Planche à découper

1 - 20

27305 4025457273056

Kunststoff · Plastic · Plastique

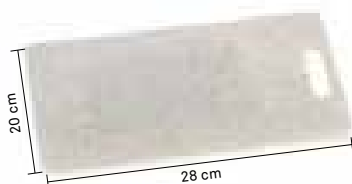

Schneidebrett Graphit

Chopping board · Planche à découper

1 - 20

27301 4025457273018

Kunststoff · Plastic · Plastique

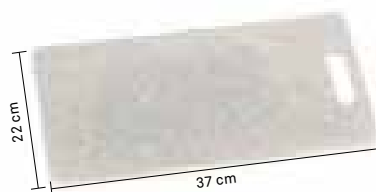

Schneidebrett Graphit

Chopping board · Planche à découper

1 - 10

27304 4025457273049

Kunststoff · Plastic · Plastique



Schneidebrett Graphit

Chopping board · Planche à découper

1 - 10

27302 4025457273025

Kunststoff · Plastic · Plastique

Maribor

Buche · Beech · Hêtre

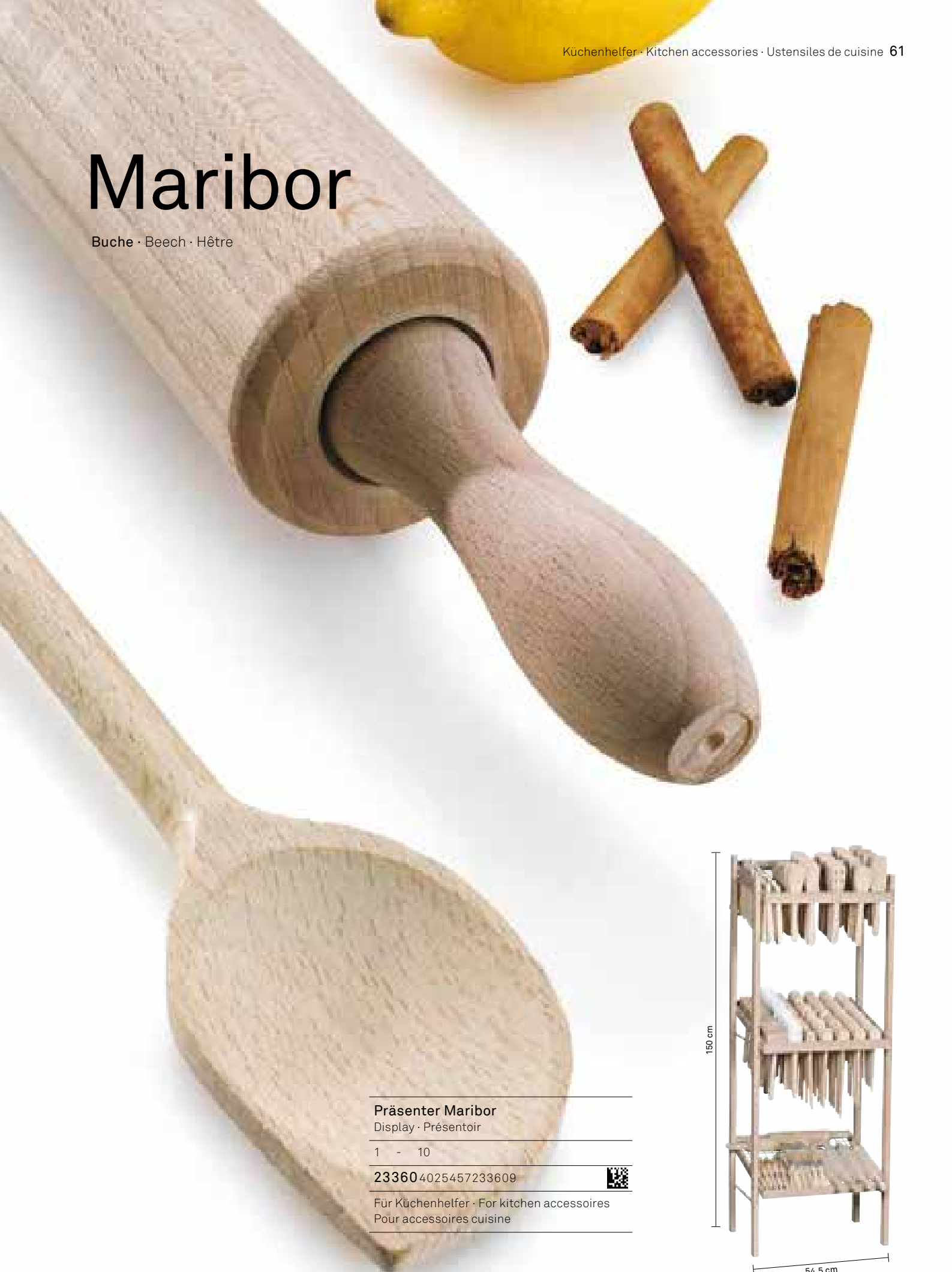

Präsenter Maribor

Display · Présentoir

1 - 10

233604025457233609



Für Küchenhelfer · For kitchen accessoires
Pour accessoires cuisine



Maribor

Buche · Beech · Hêtre

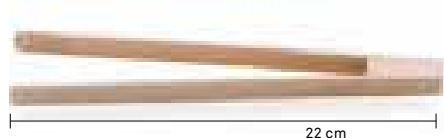

Gurkenzange

Cucumber tongs · Pince à cornichons **23349** 4025457233494 1 10 240

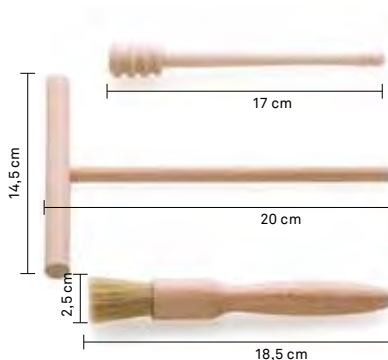

Honiglöffel

Honey spoon · Cuillère à miel **23355** 4025457233555 1 10 480



Ahorn · Maple · Erable

Crêpe-Schieber

Crêpe-slide · Spatule Crêpe **23354** 4025457233548 1 10 250



Kuchenspinsel

Cake brush · Pinceau de cuisine **23353** 4025457233531 1 5 180

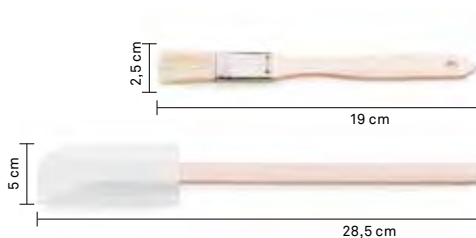

Backpinsel 1''

Baking brush · Pinceau de cuisine **23344** 4025457233449 1 20 400



Teigschaber

Dough scraper · Spatule **23342** 4025457233425 1 10 500



Gummi · Rubber · Gomme

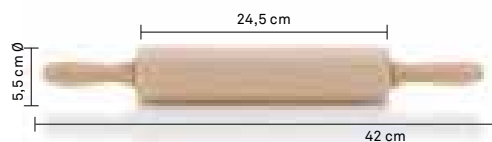

Teigroller

Rolling pin · Rouleau pâtisserie **23347** 4025457233470 1 - 12













Mörser

Mortar · Mortier **23357** 4025457233579 1 5 30



Maribor

Buche · Beech · Hêtre

Kochlöffel Kitchen spoon · Cuillère	23331 4025457233319	1	10	600	
Kochlöffel Kitchen spoon · Cuillère	23332 4025457233326	1	10	500	
Kochlöffel Kitchen spoon · Cuillère	23333 4025457233333	1	10	400	
Spitz-Lochkochlöffel Pointed hole cook spoon · Cuillère	23335 4025457233357	1	10	500	
Spitz-Kochlöffel Pointed cook spoon · Cuillère pointu	23334 4025457233340	1	10	500	
4x Set					
Kochlöffel-Set Cook spoon set · Set cuillères	17253 4025457172533	1	-	50	
Fleischhammer Meat tenderizer · Marteau à viande	23343 4025457233432	1	-	80	
Pfannenwender Spatula · Spatule	23341 4025457233418	1	10	400	
Pfannenwender Spatula · Spatule	23339 4025457233395	1	10	400	
Pfannenwender Spatula · Spatule	23340 4025457233401	1	10	450	
Pfannenwender Spatula · Spatule	23338 4025457233388	1	10	450	

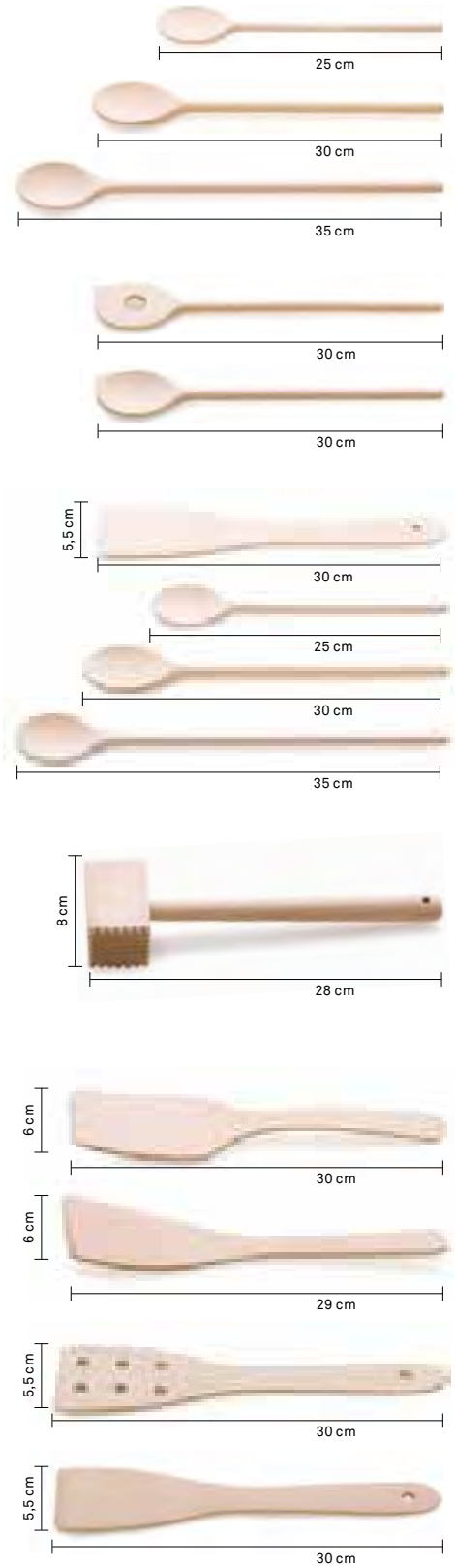

Wenn's genau sein muss



Design-Digitalküchenwaage Dieta

Digital kitchen scale · Balance digitale **16937** 4025457169373 1 - 10 



Glas, verspiegelt · Glass, metal-coating · Verre, effet brillant

Batteriebetrieben, ohne Batterien

Battery operated, without batteries · Fonctionne avec pile, pile non fournie

5 kg / 1 g

Küchenwaagen

Design-Digitalküchenwaage Livre

Digital kitchen scale · Balance digitale **16936** 4025457169366 1 - 4  

Edelstahl, matt · Stainless steel, matt · Inox, mat



Batteriebetrieben, ohne Batterien
Battery operated, without batteries · Fonctionne avec pile, sans pile

Timer-Funktion · Timer · Minuteur

5 kg / 1 g



Design-Digitalküchenwaage Peso

Digital kitchen scale · Balance digitale **16935** 4025457169359 1 - 10  



Glas, verspiegelt · Glass, metal-coating · Verre, effet brillant

Batteriebetrieben, ohne Batterien
Battery operated, without batteries · Fonctionne avec pile, sans pile

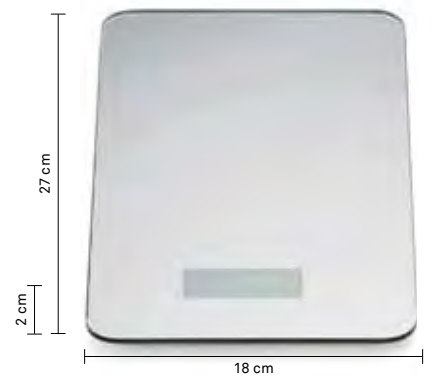
5 kg / 1 g - 10 kg / 2 g



Design-Digitalküchenwaage Pinta

Digital kitchen scale · Balance digitale **15741** 4025457157417 1 - 20  

Glas · Glass · Verre

Schwarz · Black · Noir

Batteriebetrieben, inklusive Batterien
Battery operated, batteries included · Fonctionne avec pile, pile fournie

5 kg / 1 g

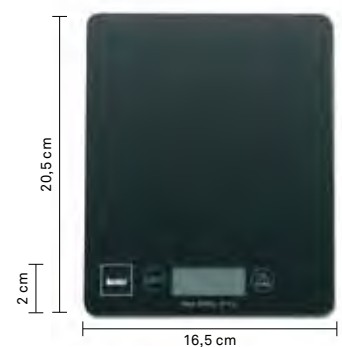

Design-Digitalküchenwaage Pinta

Digital kitchen scale · Balance digitale **15740** 4025457157400 1 - 20  **11,06** 

Glas · Glass · Verre

Weiß · White · Blanc

Batteriebetrieben, inklusive Batterien
Battery operated, batteries included · Fonctionne avec pile, pile fournie

5 kg / 1 g





Vorratsdosen

- > Praktische Vorratsdosen aus Glas und Acryl
- >> Practical storage jars in glass and acrylic
- >>> Boîtes hermétiques en verre et en acryl

Vorratsdosen

Glas, 18/10 Edelstahl
Glass, 18/10 stainless steel
Verre, 18/10 inox

Vorratsdose Baker

Storage jar · Boîte hermétique

Glas · Glass · Verre

- 6* 24 0,25 L

10765 4025457107658 

- 6* 24 0,35 L

10766 4025457107665 

Vorratsdose Baker

Storage jar · Boîte hermétique

Glas · Glass · Verre

- 4* 24 0,6 L

10767 4025457107672 

- 4* 16 1,1 L

10768 4025457107689 

- 4* 16 1,3 L

10769 4025457107696 

Vorratsdose Beria

Storage jar · Boîte hermétique

Glas · Glass · Verre

- 4* 12 1,0 L

17870 4025457178702 

- 4* 12 1,5 L

17869 4025457178696 

- 4* 12 2,0 L

17868 4025457178689 

- 4* 12 2,6 L

17867 4025457178672 

Edelstahl 18/10
Stainless steel · Inox



Edelstahl 18/10
Stainless steel · Inox



Vorratsdosen

SAN-Kunststoff · SAN-Plastic · SAN-Plastique



Vorratsdose Reva

Storage jar · Boîte hermétique

Transparent · Transparent · Transparent

- 4* 36 0,3 L

19690 4025457196904 

- 4* 24 0,6 L

19691 4025457196911 

- 4* 24 0,9 L

19692 4025457196928 

- 4* 24 1,6 L

19693 4025457196935 



Vorratsdose Tia

Storage jar · Boîte hermétique

Schwarz · Black · Noir

- 4* 36 0,5 L

15670 4025457156700 

- 4* 24 0,7 L

15671 4025457156717 

- 4* 24 1,0 L

15672 4025457156724 



Vorratsdose Tia

Storage jar · Boîte hermétique

Weiß · White · Blanc

- 4* 36 0,5 L

15675 4025457156755 

- 4* 24 0,7 L

15676 4025457156762 

- 4* 24 1,0 L

15677 4025457156779 

Vorratsdosen

SAN-Kunststoff · SAN-Plastic · SAN-Plastique

Vorratsdose San

Storage jar · Boîte hermétique

Transparent · Transparent · Transparent

- 4* 36 0,5 L

19680 4025457196805 

- 4* 24 0,7 L

19681 4025457196812 

- 4* 24 1,0 L

19682 4025457196829 

- 4* 24 1,7 L

19683 4025457196836 



Vorratsdose San

Storage jar · Boîte hermétique

Transparent · Transparent · Transparent

- 4* 24 1,0 L

19686 4025457196867 

- 4* 24 1,7 L

19687 4025457196874 



Siena

> Die komplette Besteck-Serie Siena ist aus hochwertigem, rostfreien Edelstahl 18/10 und somit optimal für die Spülmaschine geeignet. Es ist zeitlos elegant und überzeugt durch den schlichten, abgerundeten Griff.

>> The entire Siena cutlery range is made from high-grade rust-proof stainless steel 18/10 and thus ideally suited for cleaning in the dishwasher. It is timelessly elegant and convincing with its unassuming, rounded handle.

>>> Une collection complète de couverts et d'accessoires de qualité supérieure en acier inoxydable 18/10. Un design intemporel. Résistant au lave vaisselle.



Siena

18/10 Edelstahl · Stainless steel · Inox

Edelstahl 18/10
Stainless steel · Inox

27 cm

40 cm



14 cm

Kaffeelöffel-Set

Tea spoon set · Set cuillères à café

1 12 72

15951 4025457159510

6 Stück · 6 pieces · 6 pièces



25 cm

Salatbesteck

Salad servers · Couverts à salade

1 12 60

15954 4025457159541

Besteck-Set

Cutlery set · Service à couverts

1 - 10

15950 4025457159503

24-teilig · 24 pieces · 24 pièces



12 cm

Eierlöffel-Set

Egg spoon set · Set cuillères à oeuf

1 12 96

19255 4025457192555

6 Stück · 6 pieces · 6 pièces



5,5 cm

24,5 cm

Tortenheber

Cake slicer · Pelle à tarte

1 12 108

15953 4025457159534



15,5 cm

Kuchengabel-Set

Pastry fork set · Set fourchettes à gâteau

1 12 72

15952 4025 457159527

6 Stück · 6 pieces · 6 pièces



11 cm

Espressolöffel-Set

Espresso spoon set · Set cuillères espresso

1 12 96

19256 4025457192562

6 Stück · 6 pieces · 6 pièces



22,5 cm

Limonadenlöffel-Set

Lemonade spoon set · Set cuillères à limonade

1 12 96

19254 4025457192548

2 Stück · 2 pieces · 2 pièces

Einzelteile · Individual products · Pièces détachées

Tafelmesser

Knife · Couteau

19500 4025457195006 1 12 300

Tafelgabel

Fork · Fourchette

19501 4025457195013 1 12 300

Tafellöffel

Spoon · Cuillère

19502 4025457195020 1 12 300

Kaffeelöffel

Tea spoon · Cuillère à café

19503 4025457195037 1 12 600

Kuchengabel

Pastry fork · Fourchette à gâteau

19504 4025457195044 1 12 600



21,5 cm



20 cm



20 cm



14 cm



15,5 cm

Kaffee

> Für die einen ist der Kaffee am Morgen der wichtigste Programmpunkt, um überhaupt in den Tag starten zu können, für die anderen geht nichts über einen ausgezeichneten Grün-, Schwarz- oder Früchtetee.

>> For some, the most important item on the agenda to get their day off to a smooth start is a coffee, while others find you just can't beat a good cup of green, black or fruit tea.

>>> Pour les uns, le café du matin est indispensable pour bien commencer la journée, tandis que d'autres ne jurent que par le thé vert, noir ou aux fruits.





Edelstahl 18/10
Stainless steel · Inox

Milchkrug Herta 0,35 L

Milk cup · Broc à lait

1 4 24

10900 4025457109003

18/10 Edelstahl · Stainless steel · Inox



Edelstahl 18/10
Stainless steel · Inox

Milchkrug Herta 0,7 L

Milk cup · Broc à lait

1 4 12

10901 4025457109010

18/10 Edelstahl · Stainless steel · Inox



Edelstahl
Stainless steel · Inox

Kaffeebereiter Venecia 1,1 L

Coffee maker · Cafetière à piston

1 - 12

10852 4025457108525

Glas · Glass · Verre

Deckel und Siebeinsatz Edelstahl
Lid and tea filter insert stainless steel
Couvercle avec filtre inox



Edelstahl
Stainless steel · Inox

Kaffeebereiter Venecia 0,7 L

Coffee maker · Cafetière à piston

1 - 12

10851 4025457108518

Glas · Glass · Verre

Deckel und Siebeinsatz Edelstahl
Lid and tea filter insert stainless steel
Couvercle avec filtre inox



Edelstahl
Stainless steel · Inox

Teeglas Set Venecia 150 ml

Tea glasses · Verres à thé

1 - 24

10850 4025457108501

Glas · Glass · Verre

Edelstahl · Stainless steel · Inox

2-teilig · 2 pieces · 2 pièces

Espresso



Espressokanne Italia
Espresso maker · Percolateur

1 - 30

10590 4025457105906

Aluminium · Aluminum · Aluminium

3 Tassen · 3 Cups · 3 Tasses



Espressokanne Italia
Espresso maker · Percolateur

1 - 20

10591 4025457105913

Aluminium · Aluminum · Aluminium

6 Tassen · 6 Cups · 6 Tasses



Espressokanne Italia
Espresso maker · Percolateur

1 - 10

10592 4025457105920

Aluminium · Aluminum · Aluminium

9 Tassen · 9 Cups · 9 Tasses



Espressokanne Latina 200 ml
Espresso maker · Percolateur

1 - 12

10835 4025457108358

18/10 Edelstahl · Stainless steel · Inox

4 Tassen · 4 Cups · 4 Tasses



Espressokanne Latina 300 ml
Espresso maker · Percolateur

1 - 12

10836 4025457108365

18/10 Edelstahl · Stainless steel · Inox

6 Tassen · 6 Cups · 6 Tasses

> Passend für Espressokanne Italia
>> Suitable for espresso maker Italia
>>> Convient pour percolateur Italia



Ersatzdichtung Italia

Replacement gasket · Joint souple de rechange

1 - 100 für · for · pour: **10590**

10584 4025457105845

1 - 100 für · for · pour: **10591**

10585 4025457105852

1 - 100 für · for · pour: **10592**

10586 4025457105869



Teatime



Teeglas Verona 200 ml
Tea glass · Verre double paroi

1 - 24

10853 4025457108532

Glas doppelwandig
Glass double wall · Verre double paroi

Mit Edelstahl Siebeinsatz
With stainless steel tea filter
Filtre inox

2-teilig · pieces · 2 pièces

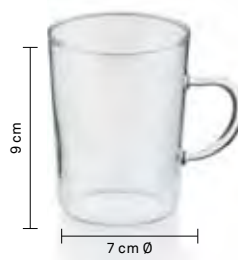

Teeglas-Set Cadro 200 ml
Tea glasses · Mug à thé

1 - 6

10755 4025457107559

Glas · Glass · Verre

4-teilig · 4 pieces · 4 pièces



Glasbecher-Set Orion 300 ml
Punch glasses · Mug à punch

1 - 6

10756 4025457107566

Glas · Glass · Verre

4-teilig · 4 pieces · 4 pièces

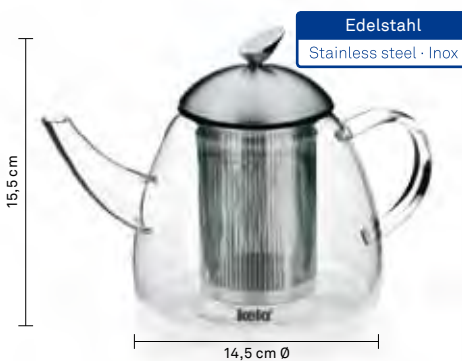

Teekanne Aurora 1,3 L
Teapot · Théière

1 - 12

16940 4025457169403

Glas · Glass · Verre

Deckel und Siebeinsatz Edelstahl
Lid and tea filter insert stainless steel
Couvercle avec filtre inox

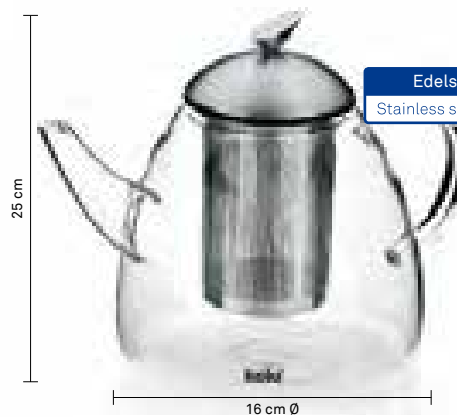

Teekanne Aurora 1,8 L
Teapot · Théière

1 - 12

16941 4025457169410

Glas · Glass · Verre

Deckel und Siebeinsatz Edelstahl
Lid and tea filter insert stainless steel
Couvercle avec filtre inox



Teekanne Cylon 1,2 L
Teapot · Théière

1 - 6

16922 4025457169229

Glas · Glass · Verre

Deckel und Siebeinsatz Edelstahl
Lid and tea filter insert stainless steel
Couvercle avec filtre inox

Sie finden unser Bowlen-Sortiment ab Seite 156

You can find our range of punch bowls
starting on page 156

Retrouvez notre collection de bol à punch
et Sangria page 156

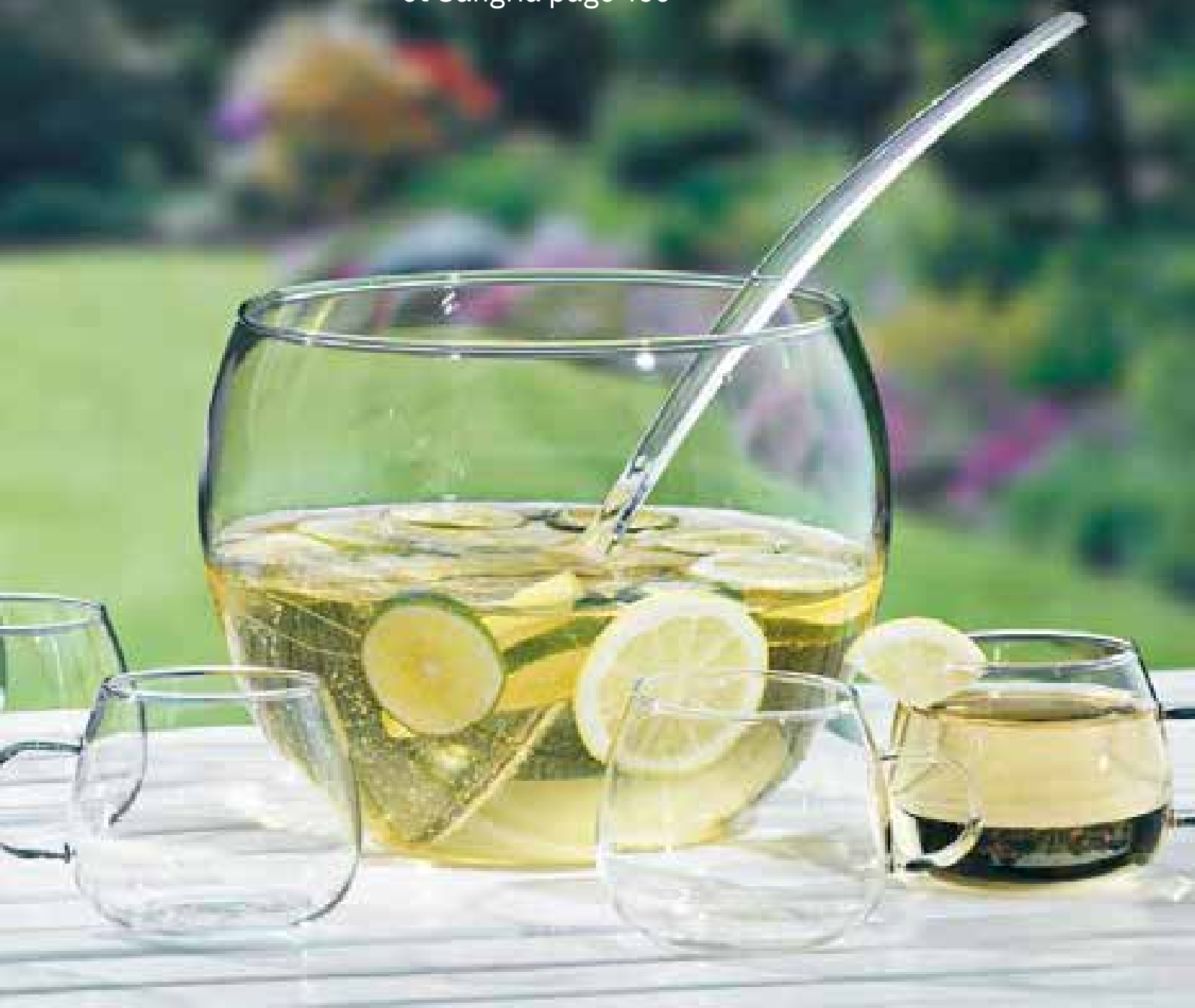

Isolierkannen

18/10 Edelstahl · Stainless steel · Inox

Edelstahl 18/10

Stainless steel · Inox

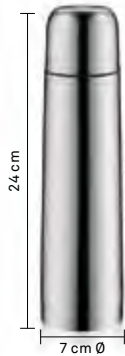

Isolierflasche Plain 0,5 L

Vacuum flask · Bouteille isotherme

1 - 24

19474 4025457194740

18/10 Edelstahl · Stainless steel · Inox

Matt · Matt · Mat

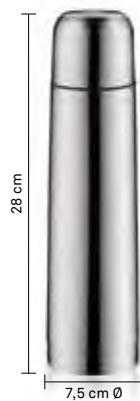

Isolierflasche Plain 0,75 L

Vacuum flask · Bouteille isotherme

1 - 20

19475 4025457194757

18/10 Edelstahl · Stainless steel · Inox

Matt · Matt · Mat

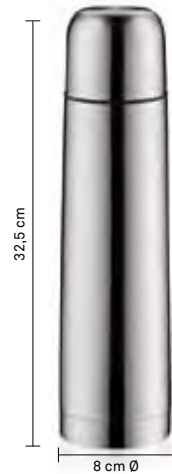

Isolierflasche Plain 1,0 L

Vacuum flask · Bouteille isotherme

1 - 20

19476 4025457194764

18/10 Edelstahl · Stainless steel · Inox

Matt · Matt · Mat



Isolierkanne Macau 1,2 L

Vacuum flask · Bouteille isotherme

1 - 6

19465 4025457194658

18/10 Edelstahl · Stainless steel · Inox

Matt · Matt · Mat

Doppelwandig

Double-walled · Paroi inox double



Isolierkanne Macau 1,5 L

Vacuum flask · Bouteille isotherme

1 - 6

19464 4025457194641

18/10 Edelstahl · Stainless steel · Inox

Matt · Matt · Mat

Doppelwandig

Double-walled · Paroi inox double



Pump-Isolierkanne Smog 1,9 L

Pump-Vacuum flask

Bouteille isotherme à pompe

1 - 6

19621 4025457196218

18/10 Edelstahl · Stainless steel · Inox

Matt · Matt · Mat

Glaseinsatz · Glass insert · Intérieur verre



Saftpresse California

Juice squeezer · Presse agrumes

1 - 6

40081 4025457400810

Metall verchromt · Metal chromed · Métal chromé

Becher, Presse und Presskegel aus Edelstahl
Cup, press and press cone, stainless steel
Gobelet, presse et cône inox



Cocktail Shaker Florida 0,5 L

Cocktail Shaker · Cocktail shaker

1 - 30

17810 4025457178108

18/10 Edelstahl · Stainless steel · Inox

Matt · Matt · Mat

Mit Siebeinsatz · Container with filter insert
Avec filtre et couvercle



Flaschenhalter Loop

Bottle holder · Porte-bouteilles

1 - 24

49279 4025457492792

Metall verchromt · Metal chromed · Métal chromé



Sektkühler Chicago

Champagne cooler · Seau à champagne

1 6 24

17806 4025457178061

Aluminium · Aluminium · Aluminium



Sektkühler Dallas

Champagne cooler · Rafrâchisseur

1 - 12

17802 4025457178023

Kunststoff · Plastic · Plastique

Transparent · Transparent · Transparent



Sektkühler Dallas

Champagne cooler · Rafrâchisseur

1 - 12

15938 4025457159381

Kunststoff · Plastic · Plastique

Schwarz · Black · Noir

Nova

12 Stück im Display · 12 pieces in display · 12 pièces par display



Edelstahl 18/10
Stainless steel · Inox

Tropfenfänger
Drip catcher · Pare gouttes

1 - 12 (EPr.)

19153 4025457191534

18/10 Edelstahl · Stainless steel · Inox

2-er Set · 2 pieces · Set 2 pièces



Edelstahl 18/10
Stainless steel · Inox

Flaschenverschluss
Bottle closure · Bouchon bouteille

1 - 12 (EPr.)

19150 4025457191503

18/10 Edelstahl · Stainless steel · Inox

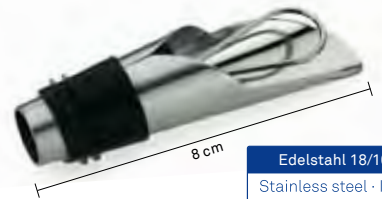

Edelstahl 18/10
Stainless steel · Inox

Flaschenausgießer
Liquor pourer · Bec verseur

1 - 12 (EPr.)

19174 4025457191749

18/10 Edelstahl · Stainless steel · Inox

Mit Stopper · With stopper · Avec stop goutte



Edelstahl 18/10
Stainless steel · Inox

Sektflaschenverschluss
Bottle closure for sparkling wine
Bouchon pour bouteille à champagne

1 - 12 (EPr.)

19151 4025457191510

Metall verchromt · Metal chromed · Métal chromé



Edelstahl 18/10
Stainless steel · Inox

Kellnerkorkenzieher
Waiter's corkscrew · Tire bouchon

1 - 12 (EPr.)

19152 4025457191527

Kunststoffschale · Cover plastic · Plastique

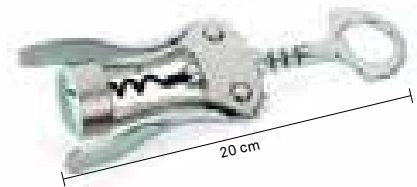

Edelstahl 18/10
Stainless steel · Inox

Korkenzieher
Corkscrew · Tire Bouchon

1 - 8 (EPr.)

19184 4025457191848

Vernickelt, Spirale beschichtet
Nickel plated, spiral coated
Nickelé, spirale pelliculée

6 Stück im Display
6 pieces in display · 6 pièces par display

Moreno

› Die Brotkörbe der Serie Moreno sind hochwertig verarbeitet.

Außerdem ist der Baumwolleinsatz wend- und waschbar.

› The bread baskets in the Moreno range are crafted to the highest quality standards. And the cotton insert is reversible and washable.

›› Les corbeilles à pain de la série Moreno présentent une finition de qualité. De plus, la partie en coton est réversible et lavable.



Moreno

Metall, 100 % Baumwolle · Metal, 100 % Cotton · Métal, 100 % Coton



Brotkorb
Bread basket · Corbeille à pain

1 - 20

10935 4025457109355



Metall, Baumwolle · Metal, cotton · Métal, coton

Braun · Brown · Brun



Brotkorb
Bread basket · Corbeille à pain

1 - 12

10936 4025457109362



Metall, Baumwolle · Metal, cotton · Métal, coton

Braun · Brown · Brun



Brotkorb
Bread basket · Corbeille à pain

1 - 12

10937 4025457109379



Metall, Baumwolle · Metal, cotton · Métal, coton

Braun · Brown · Brun



Brotkorb
Bread basket · Corbeille à pain

1 - 20

10938 4025457109386



Metall, Baumwolle · Metal, cotton · Métal, coton

Schwarz · Black · Noir



Brotkorb
Bread basket · Corbeille à pain

1 - 12

10939 4025457109393



Metall, Baumwolle · Metal, cotton · Métal, coton

Schwarz · Black · Noir



Brotkorb
Bread basket · Corbeille à pain

1 - 12

10940 4025457109409



Metall, Baumwolle · Metal, cotton · Métal, coton

Schwarz · Black · Noir



Drahtartikel

› Drahtartikel in ansprechender Optik.

›› Eye-catching wire articles.

››› Une collection élégante et recherchée.

Cesto

Metall verchromt · Metal chromed · Métal chromé

Fruchtkorb

Fruit basket · Corbeille à fruits

1 - 16

10816 4025457108167



Metall verchromt · Metal chromed · Métal chromé



Fruchtkorb

Fruit basket · Corbeille à fruits

1 - 12

10819 4025457108198



Metall verchromt · Metal chromed · Métal chromé

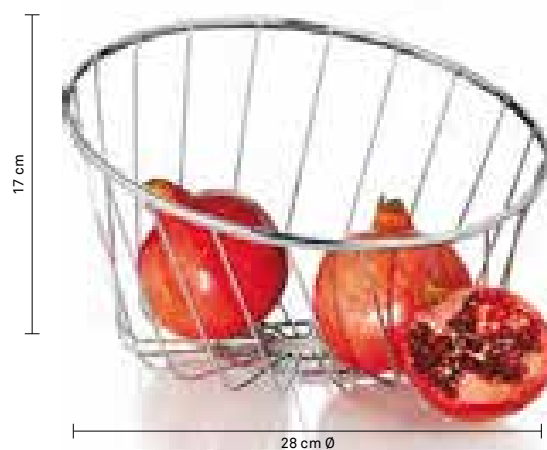

Fruchtkorb

Fruit basket · Corbeille à fruits

1 - 24

10818 4025457108181



Metall verchromt · Metal chromed · Métal chromé

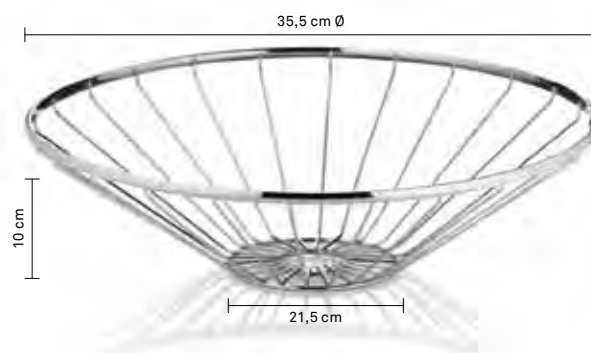

Impuls

Metall verchromt · Metal chromed · Métal chromé

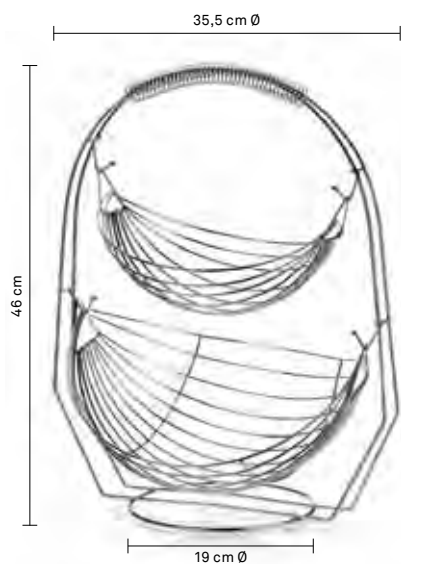

Fruchtkorb Impuls

Fruit basket · Corbeille à fruits

1 - 6

15765 4025457157653

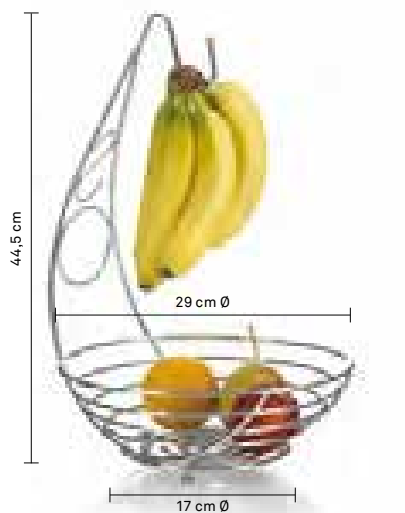

Fruchtkorb Impuls

Fruit basket · Corbeille à fruits

1 - 6

17586 4025457175862

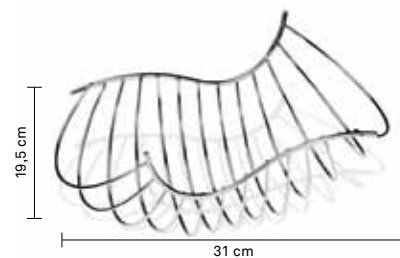

Fruchtkorb Impuls

Fruit basket · Corbeille à fruits

1 - 4

15790 4025457157905

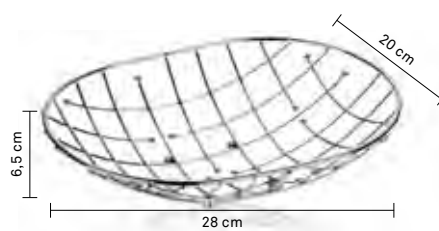

Fruchtkorb Impuls

Fruit basket · Corbeille à fruits

1 - 24

15768 4025457157684

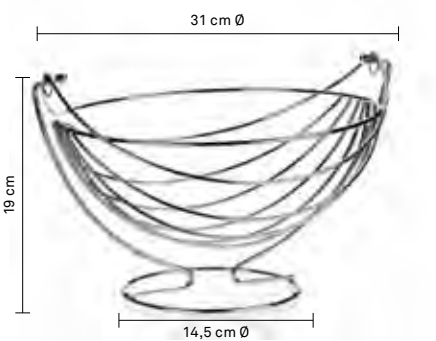

Fruchtkorb Impuls

Fruit basket · Corbeille à fruits

1 - 6

15766 4025457157660

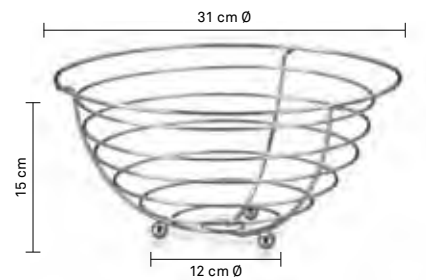

Fruchtkorb Impuls

Fruit basket · Corbeille à fruits

1 - 24

17585 4025457175855



Ferro/Canasto

Metall verchromt · Metal chromed · Métal chromé

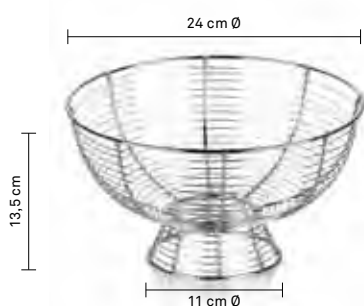

Fruchtkorb Ferro
Fruit basket · Corbeille à fruits

1 - 12

15306 4025457153068

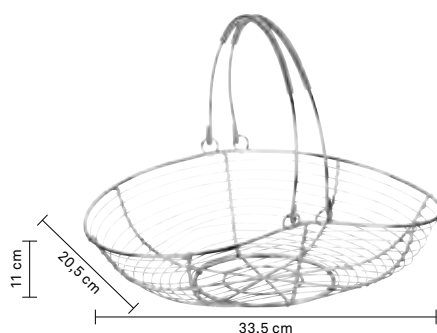

Fruchtkorb Ferro
Fruit basket · Corbeille à fruits

1 - 24

15308 4025457153082

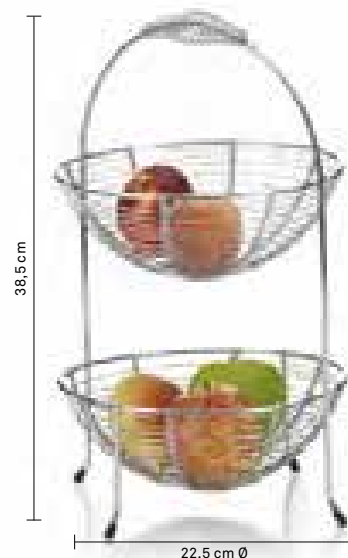

Etagere Ferro
Etagere · Etagère à fruits

1 - 6

15310 4025457153105

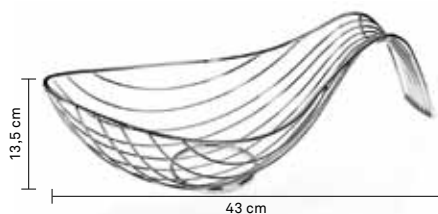

Fruchtkorb Canasto
Fruit basket · Corbeille à fruits

1 - 12

16927 4025457169274

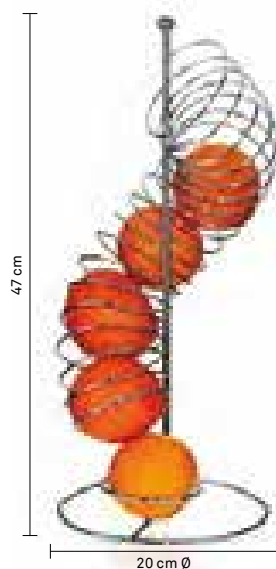

Fruchtspender Canasto
Fruit dispenser · Distributeur à fruits

1 - 12

16928 4025457169281

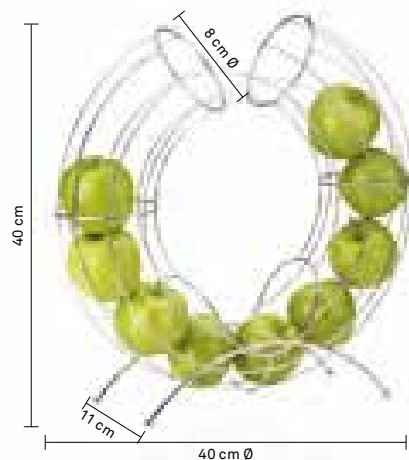

Fruchtspender Canasto
Fruit dispenser · Distributeur à fruits

1 - 4

15548 4025457155482





Prisma

Metall verchromt · Metal chromed · Métal chromé

> Die Küchenregalserie Prisma ist in der Optik leicht und elegant. Dazu kommt die hochwertige Verarbeitung von Prisma: Die Abschlüsse sind aus Flachstahl gefertigt, ohne störende Ecken und Kanten. Zu Prisma gehören vielfältige Regalkomponenten für die Prisma Hängeleiste sowie weitere Küchenausstattung.

>> The Prisma kitchen rack series has an air of lightness and elegance. Add to this the excellent Prisma craftsmanship: The ends are made of flat-rolled steel, no annoying corners and edges. Prisma encompasses a great variety of rack components for the Prisma hanging rail and other kitchen equipment.

>>> La Collection Prisma est élégante et recherchée. Les finitions en métal plat la rende agréable. Prisma permet de combiner les accessoires choisis.

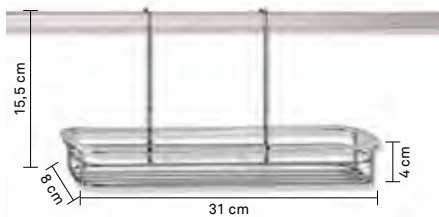

Gewürzregal

Spice rack · Etagère à épices

1 - 8

19630 4025457196300

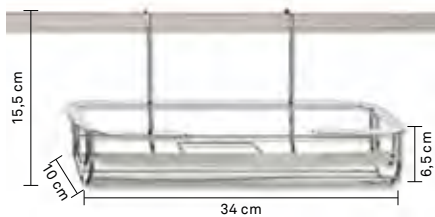

Folienhalter

Foil holder · Porte-film alimentaire

1 - 6

19631 4025457196317



Hängeregale

Hanging rack · Etagère à suspendre

1 - 6

19635 4025457196355



Haken-Set S-Form

Hooks S-form · Crochets forme S

1 - 36

19634 4025457196348

6 Stück · 6 pieces · 6 pièces

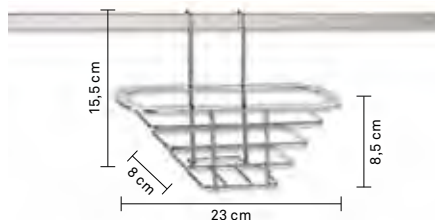

Filtertütenkorb

Filter bag basket · Corbeille pour filtres à café

1 - 8

19632 4025457196324

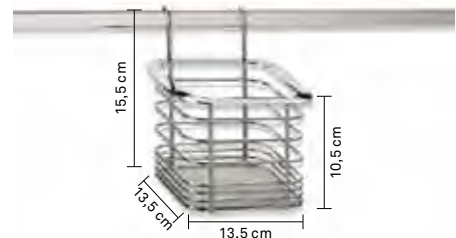

Utensilienhalter

Hanging rack · Suspension panier

1 - 8

19639 4025457196393

Prisma

Metall verchromt · Metal chromed · Métal chromé

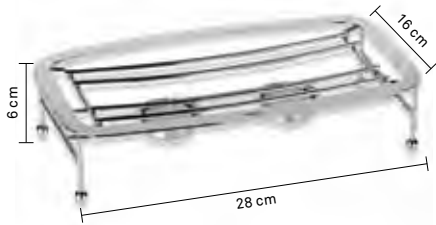

Stövchen

Teapot warmer · Chauffe-Plat

1 - 24

19644 4025457196447

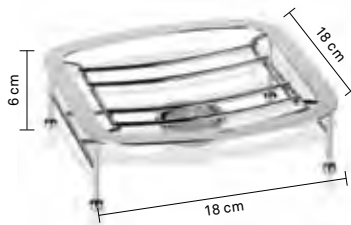

Stövchen

Teapot warmer · Chauffe-Plat

1 - 24

19646 4025457196461

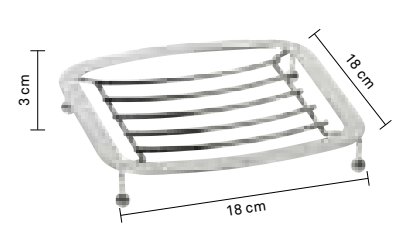

Untersetter

Table mat · Dessous-de-plat

1 - 36

19640 4025457196409

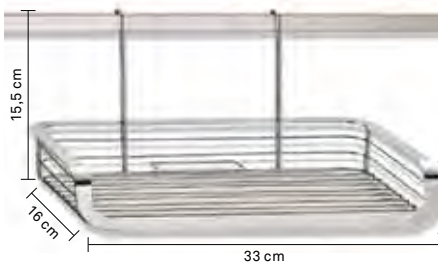

Hängeregal offen

Hanging rack · Etagère à suspendre

1 - 4

19633 4025457196331

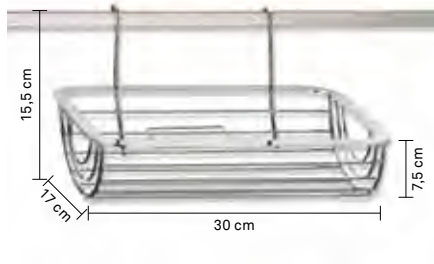

Küchenrollenhalter

Kitchen roll holder · Support à essuie-tout

1 - 4

19638 4025457196386

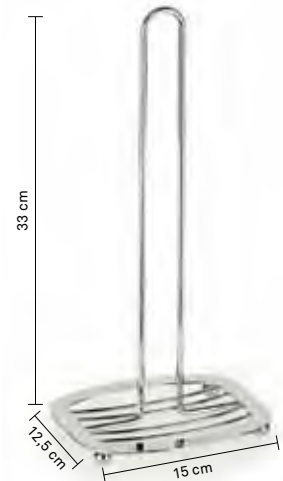

Küchenrollenhalter

Kitchen roll holder · Support à essuie-tout

1 - 18

19641 4025457196416

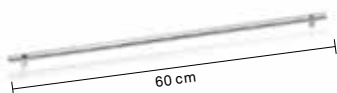

Hängeleiste 60 cm

Hanging Bar · Barre de suspension

1 - 24

19637 4025457196379

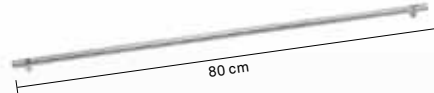

Hängeleiste 80 cm

Hanging Bar · Barre de suspension

1 - 18

19636 4025457196300

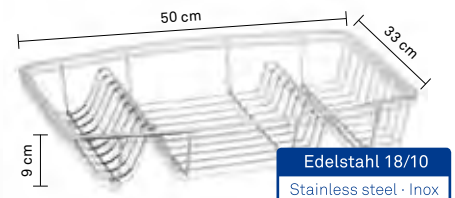

Geschirrabtropfkorb

Draining basket et for dishes

Egouttoir à vaisselle

1 - 6

19645 4025457196454



18/10 Edelmetall · Stainless steel · Inox

Passend für · Suitable for · Pour ref 15442

- 1x Eckverbinder · Verlängerungsverbinder
- 2x Abdeckkappen
- 1x Corner connector · Extension connector
- 2x Covering cap
- 1x Connecteur coin · 1x Rallonge · 2x Caches

- 1x Eckverbinder · Verlängerungsverbinder
- 2x Abdeckkappen
- 1x Corner connector · Extension connector
- 2x Covering cap
- 1x Connecteur coin · 1x Rallonge · 2x Caches

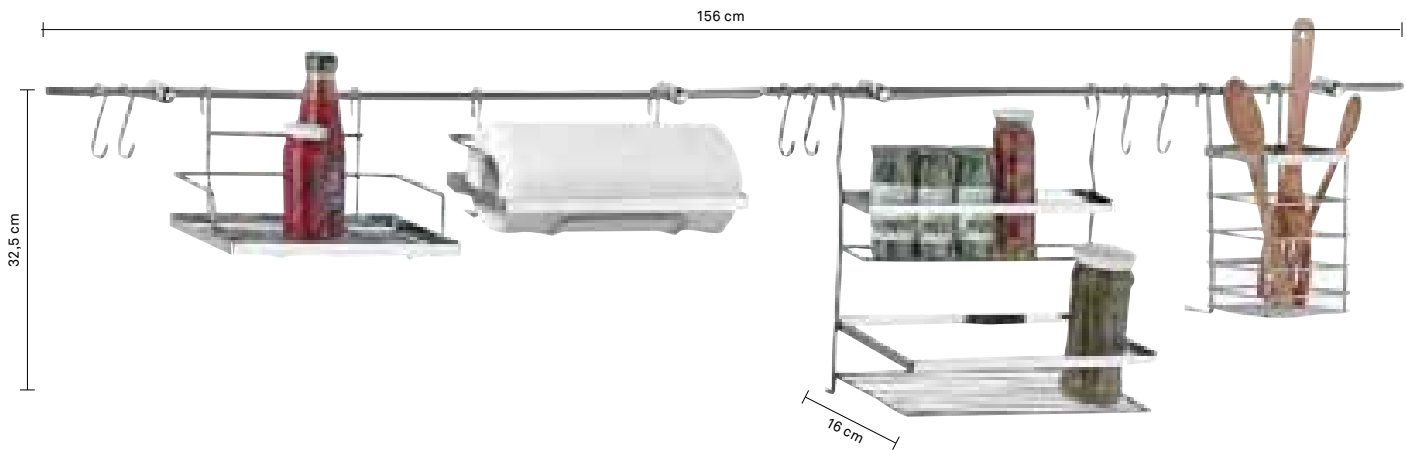

Küchen-Set Flex

Kitchen-set · Set cuisine

19428 4025457194283 1 - 6



Metall verchromt · Metal chromed · Métal chromé

14-teilig · 14 pieces · 14 pièces

6x S-Haken, 4x Stangen á 78 cm, 1x Korb, 1x Doppelregal, 1x Küchentuchhalter, 1x Ablage
 1x Hooks S-form, 4x Bars á 78 cm, 1x Basket, 1x Double rack 1x Kitchen holder, 1x Clipboard
 1x Crochets forme-S, 4x Tiges á 78 cm, 1x Panier, 1x Etagère double, 1x Porte-torchons
 1x Etagère

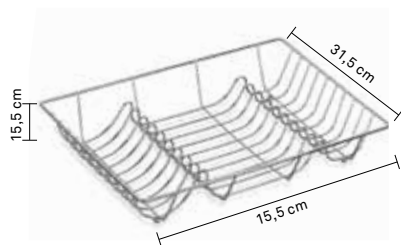

Geschirrabtropfkorb Loop

Draining basket for dishes
 Egouttoir à vaisselle

1 - 12

49553 4025457495533

Metall verchromt · Metal chromed · Métal chromé

Passend für · Suitable for · Pour ref 15442



Edelstahl 18/10
 Stainless steel · Inox

Tablett für Geschirrabtropfkorb Prisma

Tray for draining basket
 Plateau sous égouttoir

1 - 24

15442 4025457154423

18/10 Edelstahl · Stainless steel · Inox

Passend für · Suitable for · Pour réf
 19645, 49553

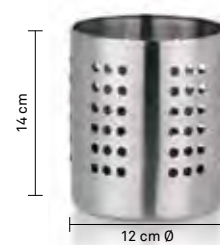

Edelstahl 18/10
 Stainless steel · Inox

Besteckabtropfkorb Profi

Cutlery holder · Egouttoir à couvert

1 12 24

15803 4025457158032

18/10 Edelstahl · Stainless steel · Inox

Matt · Mat · Mat

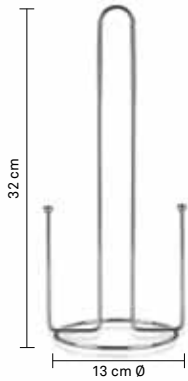

Küchenrollenhalter Globul
Kitchen roll holder · Support à essuie-tout

1 - 12

17582 4025457175824

Metall verchromt · Metal chromed · Métal chromé

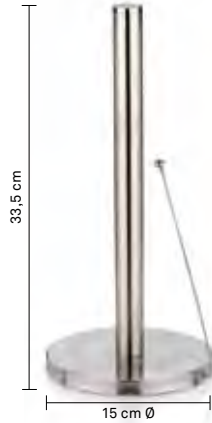

Küchenrollenhalter Rollo
Kitchen roll holder · Support à essuie-tout

1 - 12

16920 4025457169205

Edelstahl · Stainless steel · Inox

Matt · Matt · Mat

Edelstahl
Stainless steel · Inox

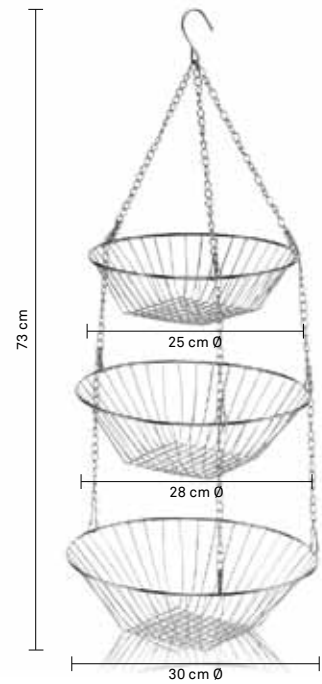

Drahtetägere Loop
Hanging basket · Etagère panier

1 - 12

49552 4025457495526

Metall verchromt · Metal chromed · Métal chromé

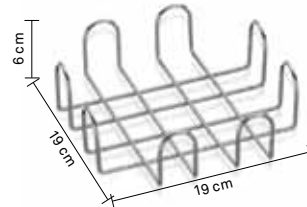

Serviettenhalter Globul
Napkin holder · Porte-serviette

1 - 24

17581 4025457175817

Metall verchromt · Metal chromed · Métal chromé

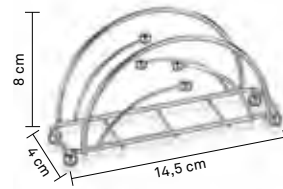

Serviettenhalter Globul
Napkin holder · Porte-serviette

1 - 48

17550 4025457175503

Metall verchromt · Metal chromed · Métal chromé

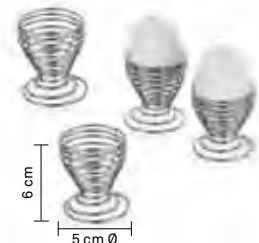

Eierbecher-Set Globul
Egg cups set · Set coquetiers

1 - 48

17580 4025457175800

4 Stück · 4 pieces · 4 pièces

Metall verchromt · Metal chromed · Métal chromé

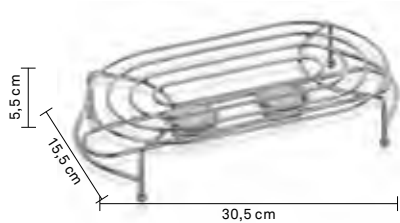

Stövchen Globul
Teapot warmer · Chauffe-Plat

1 - 24

17601 4025457176012

Metall verchromt · Metal chromed · Métal chromé

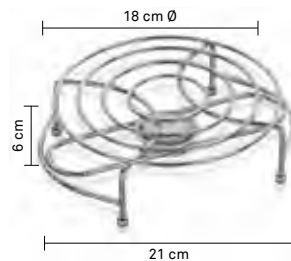

Stövchen Globul
Teapot warmer · Chauffe-Plat

1 - 24

17600 4025457176005

Metall verchromt · Metal chromed · Métal chromé

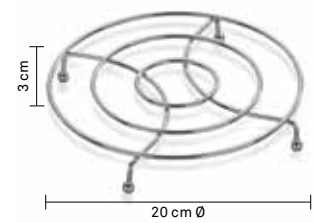

Untersetzer Globul
Table mat · Dessous-de-plat

1 - 24

17602 4025457176029

Metall verchromt · Metal chromed · Métal chromé



Flaschenträger Loop

Bottle holder · Porte-bouteilles

1 - 10

49880 4025457498800



Metall verchromt · Metal chromed · Métal chromé

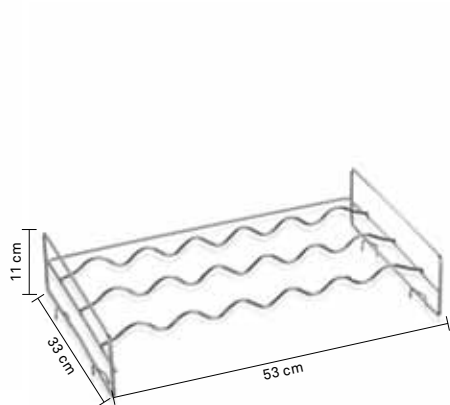

Flaschenregal Loop

Bottle rack · Etagère à bouteilles

1 - 8

49645 4025457496455



Metall verchromt · Metal chromed · Métal chromé

Stapelbar · Stackable · Empilable

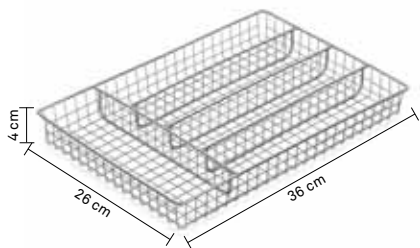

Besteckkasten Loop

Cutlery box · Range couverts

1 - 12

49551 4025457495519



5 Fächer · 5 Inserts · 5 Compartiments

Metall verchromt · Metal chromed · Métal chromé

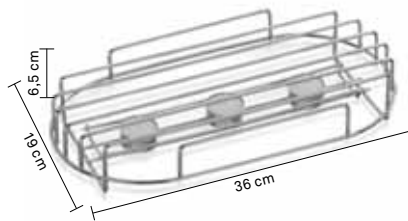

Stövchen Mira

Teapot warmer · Chauffe-Plat

1 - 18

17628 4025457176289



Metall verchromt · Metal chromed · Métal chromé

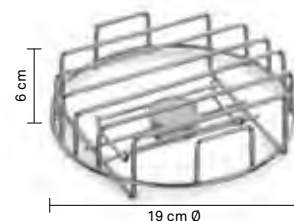

Stövchen Mira

Teapot warmer · Chauffe-Plat

1 - 36

17627 4025457176272



Metall verchromt · Metal chromed · Métal chromé

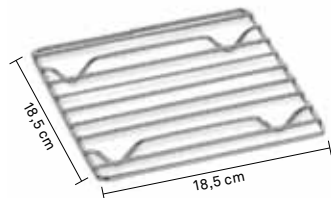

Untersetzer Mira

Table mat · Dessous-de-plat

1 - 48

17626 4025457176265



Metall verchromt · Metal chromed · Métal chromé

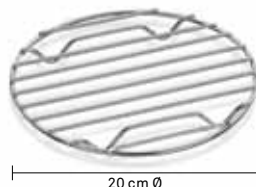

Untersetzer Mira

Table mat · Dessous-de-plat

1 - 48

17625 4025457176258



Metall verchromt · Metal chromed · Métal chromé

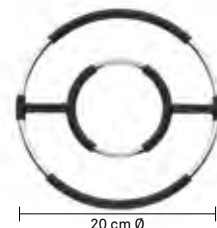

Untersetzer Globul

Table mat · Dessous-de-plat

1 - 12

15792 4025457157929



Mit Silikon · With silicone · Avec silicone

Metall verchromt · Metal chromed · Métal chromé

Schwarz · Black · Noir



Wohnaccessoires

- > Nützlich und schick ist hier die Aussage! Kela führt Wohnaccessoires für den kompletten Haushalt.
- >> Useful and elegant design Kela has the lifestyle accessories for your entire home.
- >>> Kela propose des accessoires utiles et chics pour toute la maison.

Kela

Wanduhren

Edelstahl, batteriebetrieben, ohne Batterie

Stainless steel, battery operated, without battery

Inox, fonctionne avec pile, sans pile

Edelstahl

Stainless steel · Inox

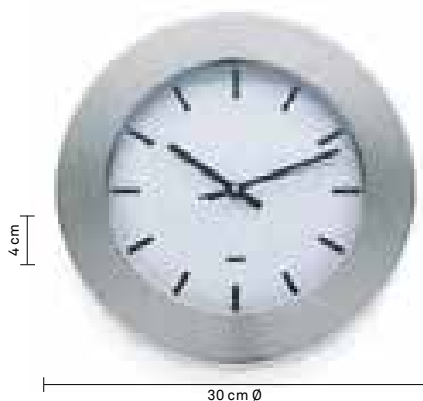

Wanduhr New York

Wall clock · Horloge murale

1 - 10

17151 4025457171512

Edelstahl · Stainless steel · Inox

Matt · Matt · Mat

Weiß · White · Blanc



Wanduhr Kabul

Wall clock · Horloge murale

1 - 10

17158 4025457171581

Edelstahl · Stainless steel · Inox

Matt · Matt · Mat

Schwarz · Black · Noir



Wanduhr Luanda

Wall clock · Horloge murale

1 - 10

17157 4025457171574

Edelstahl · Stainless steel · Inox

Matt · Matt · Mat

Türkis · Turquoise · Turquoise



Wanduhr Kairo

Wall clock · Horloge murale

1 - 10

17156 4025457171567

Edelstahl · Stainless steel · Inox

Matt · Matt · Mat

Grün · Green · Vert



Wanduhr Dublin

Wall clock · Horloge murale

1 - 10

17155 4025457171550

Edelstahl · Stainless steel · Inox

Matt · Matt · Mat

Brombeer · Blackberry · Mûre

Wanduhren

Batteriebetrieben, ohne Batterie · Battery operated, without battery · Fonctionne avec pile, sans pile

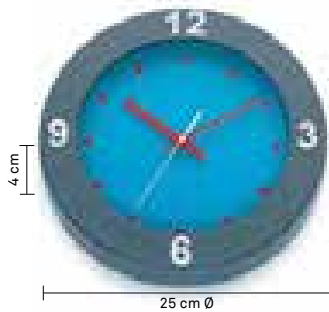

Wanduhr Valletta

Wall clock · Horloge murale

1 - 20

22502 4025457225024

Metall · Metal · Métal

Blau · Blue · Bleu



Wanduhr Vaduz

Wall clock · Horloge murale

1 - 20

22503 4025457225031

Metall · Metal · Métal

Grün · Green · Vert



Wanduhr Pretoria

Wall clock · Horloge murale

1 - 20

22504 4025457225048

Metall · Metal · Métal

Koralle · Coral · Corail

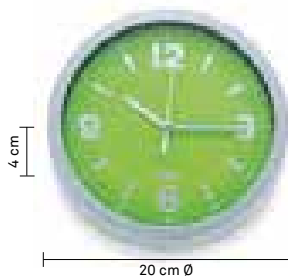

Wanduhr Oslo

Wall clock · Horloge murale

1 - 20

21293 4025457212932

Kunststoff · Plastic · Plastique

Grün · Green · Vert



Wanduhr Berlin

Wall clock · Horloge murale

1 - 20

17162 4025457171628

Kunststoff · Plastic · Plastique

Schwarz · Black · Noir



Wanduhr Paris

Wall clock · Horloge murale

1 - 20

17161 4025457171611

Kunststoff · Plastic · Plastique

Weiß · White · Blanc



Wanduhr Athen

Wall clock · Horloge murale

1 - 20

21297 4025457212970

Kunststoff · Plastic · Plastique

Brombeer · Blackberry · Mûre



Wanduhr Moskau

Wall clock · Horloge murale

1 - 20

17159 4025457171598

Kunststoff · Plastic · Plastique

Rot · Red · Rouge



Wanduhr Tokyo

Wall clock · Horloge murale

1 - 20

17160 4025457171604

Kunststoff · Plastic · Plastique

Türkis · Turquoise · Turquoise

Wanduhren

Batteriebetrieben, ohne Batterie
 Battery operated, without battery
 Fonctionne avec pile, sans pile



Wanduhr Manila
 Wall clock · Horloge murale

1 - 40

22500 4025457225000

Kunststoff · Plastic · Plastique

Schwarz · Black · Noir

Zum Hängen und Stellen
 Wall mounted and free standing
 A accrocher et à poser



Wanduhr Peru
 Wall clock · Horloge murale

1 - 40

22501 4025457225017

Kunststoff · Plastic · Plastique

Weiß · White · Blanc

Zum Hängen und Stellen
 Wall mounted and free standing
 A accrocher et à poser



Wanduhr Rom
 Wall clock · Horloge murale

1 - 20

17152 4025457171529

Edelstahl · Stainless steel · Inox

Matt · Matt · Mat



Wanduhr Sydney
 Wall clock · Horloge murale

1 - 10

17150 4025457171505

Edelstahl · Stainless steel · Inox

Matt · Matt · Mat

Trolleys

Bambus · Bamboo · Bambou

Edelstahl 18/10

Stainless steel · Inox



Trolley Mina

Trolley table · Trolley

1 - 1

17503 4025457175039

2x Schublade · Drawer · Tiroir
2x Drahtkorb · Wire-basket · Corbeille fil de fer
1x Fachboden · Board · Sol

Trolley Grete

Trolley table · Trolley au sol

1 - 1

17501 4025457175015

1x Schublade · Drawer · Tiroir
1x Drahtkorb · Wire-basket · Corbeille fil de fer
1x Fachboden · Board · Sol
1x Flaschenablage · Bottle-board · Porte-bouteille

Gießkannen

Edelstahl glänzend · Stainless steel bright · Inox brillant

Edelstahl
Stainless steel · Inox

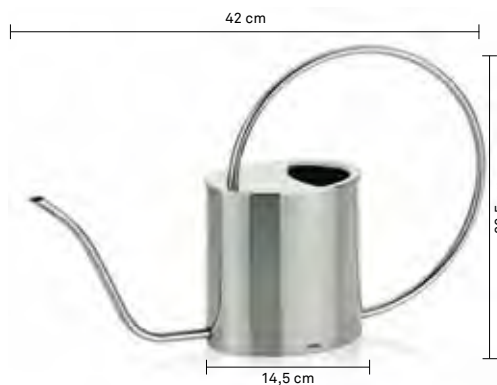

Gießkanne Fleur 1,5 L
Watering can · Arrosoir

1 - 4

18802 4025457188022

Edelstahl · Stainless steel · Inox

Glänzend · Bright · Brillant



Gießkanne Kreta 0,9 L
Watering can · Arrosoir

1 - 8

18813 4025457188138

Edelstahl · Stainless steel · Inox

Glänzend · Bright · Brillant

Mit neuem Ausgießsystem
With new effusing system
Avec nouveau système d'arrosage



Gießkanne Korfu 0,9 L
Watering can · Arrosoir

1 - 8

18812 4025457188121

Edelstahl · Stainless steel · Inox

Glänzend · Bright · Brillant

Mit neuem Ausgießsystem
With new effusing system
Avec nouveau système d'arrosage

Schirmständer

Schirmständer Swing

Umbrella stand · Porte-parapluie

1 - 2 

18031 4025457180316 

Edelstahl · Stainless steel · Inox

Matt · Matt · Mat

Schirmständer Swing

Umbrella stand · Porte-parapluie

1 - 2 

21889 4025457218897 

Edelstahl · Stainless steel · Inox

Glänzend · Bright · Brillant

Schirmständer Linda

Umbrella stand · Porte-parapluie

1 - 2 

21365 4025457213656 

Metall farbig beschichtet
Metal colour coated
Métal revêtement couleur

Weiß · White · Blanc

Schirmständer Graphit

Umbrella stand · Porte-parapluies

1 - 2 

21364 4025457213649 

Metall farbig beschichtet
Metal colour coated
Métal revêtement couleur

Schwarz · Black · Noir



Aufbewahren

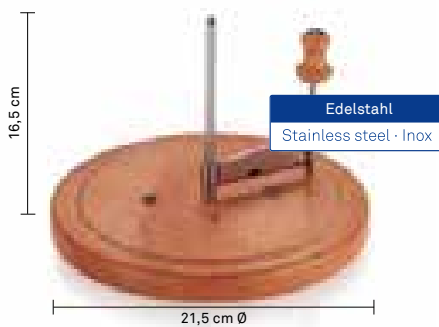

Käsehobler Luxus
Cheese scraper · Girolle à fromage

1 - 12

77085 4025457770852

Edelstahl · Stainless steel · Inox

Buche · Beech · Hêtre



Glashaube Luxus
Glass cover · Couvercle en verre

1 - 6

17651 4025457176517

Glas · Glass · Verre

Zu Käsehobler · Usable for cheese scraper ·
Pour girolle à fromage: **77085**

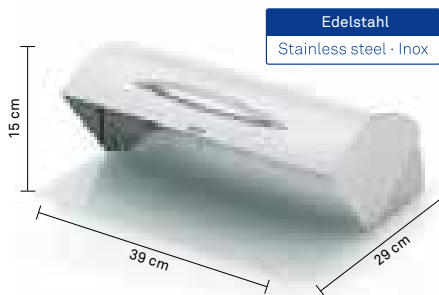

Brotkasten Farina
Bread box · Boîte à pain

1 - 2

15775 4025457157752

Edelstahl · Stainless steel · Inox

Glasplatte · Glass plate · Plaque en verre

Weiß · White · Blanc

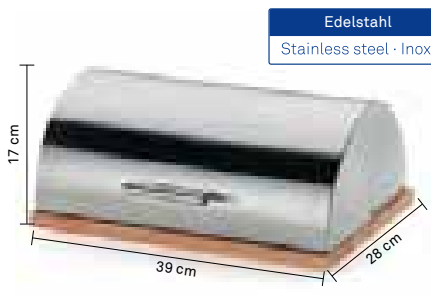

Brotkasten De Luxe
Bread box · Boîte à pain

1 - 2

19210 4025457192104

Edelstahl · Stainless steel · Inox

Matt · Matt · Mat

Holzplatte · Baseplate wood · Socle bois

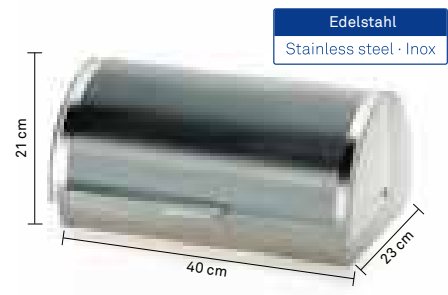

Brotkasten Style
Bread box · Boîte à pain

1 - 3

15303 4025457153037

Edelstahl · Stainless steel · Inox

Matt · Matt · Mat

PS-Kunststoff · PS-Plastic · PS-Plastique



Treteimer

> Bio, Wertstoff, Kunststoff, Restmüll: Bei der Abfallfrage hat heutzutage jeder sein eigenes Konzept. Welches Abfallkonzept Sie auch immer verfolgen – bei Kela gibt es die passenden Mülleimer dazu.

>> Organic waste, plastic, and residual waste: Everyone has their own system when it comes to waste. Whichever waste concept you may have – Kela has the right waste bins for you.

>>> Chacun a sa manière de faire son tri sélectif. Kela vous propose un grand choix de poubelles.

Angelo

Edelstahl · Stainless steel · Inox

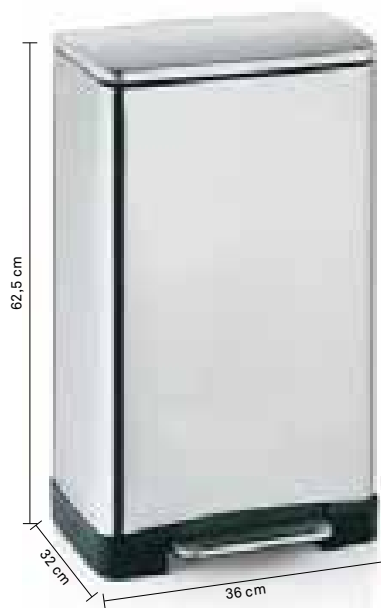

Treteimer 20 L

Pedal bin · Poubelle à pédale

1 - 1 

11536 4025457115363 

Edelstahl · Stainless steel · Inox

Matt · Matt · Mat

Treteimer 30 L

Pedal bin · Poubelle à pédale

1 - 1 

17175 4025457171758 

Edelstahl · Stainless steel · Inox

Matt · Matt · Mat

Treteimer 46 L

Pedal bin · Poubelle à pédale

1 - 1 

11538 4025457115387 

Zwei Kammern 28 L und 18 L
Two compartments 28 L and 18 L
Deux compartiments de 28 L et 18 L

Edelstahl · Stainless steel · Inox

Matt · Matt · Mat

Franco

Edelstahl · Stainless steel · Inox

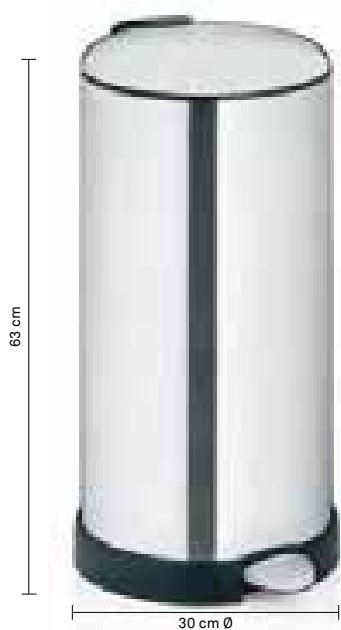

Treteimer 27 L

Pedal bin · Poubelle à pédale

1 - 2 

17180 4025457171802 

Edelstahl · Stainless steel · Inox

Matt · Matt · Mat



Pasador

Deckel und Boden aus Kunststoff schwarz

Lid and stand: PP-Plastic, black

Couvercle et socle: PP-Plastique, noir



Edelstahl
Stainless steel · Inox

Tret- und Pusheimer 40 L

Pedal and push bin

Poubelle à pédale ou pression

1 - 1

17132 4025457171321

Edelstahl · Stainless steel · Inox

Matt · Matt · Mat



Tret- und Pusheimer 40 L

Pedal and push bin

Poubelle à pédale ou pression

1 - 1

17141 4025457171413

Stahlblech beschichtet
Steel powder coated
Acier revêtement couleur

Grau · Grey · Gris



Tret- und Pusheimer 40 L

Pedal and push bin

Poubelle à pédale ou pression

1 - 1

17138 4025457171383

Stahlblech beschichtet
Steel powder coated
Acier revêtement couleur

Beige · Beige · Beige



Tret- und Pusheimer 40 L

Pedal and push bin

Poubelle à pédale ou pression

1 - 1

17135 4025457171352

Stahlblech beschichtet
Steel powder coated
Acier revêtement couleur

Rot · Red · Rouge

Delta

Stahlblech beschichtet
Steel powder coated
Acier revêtement couleur



Treteimer 15 L

Pedal bin · Poubelle à pédale

1 - 1

11535 4025457115356

Edelstahl · Stainless steel · Inox

Matt · Matt · Mat

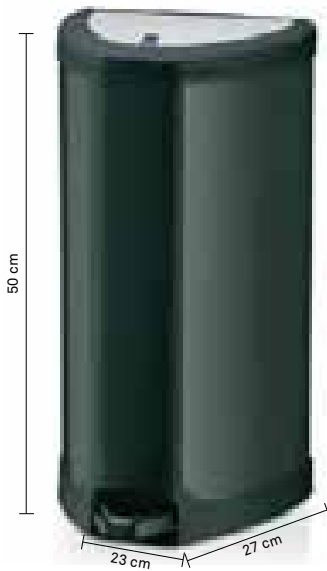

Treteimer 15 L

Pedal bin · Poubelle à pédale

1 - 1

17139 4025457171390

Deckel und Boden aus Kunststoff schwarz
Lid and Stand: PP-Plastic, black
Couvercle et socle: PP-Plastique, noir

Grau · Grey · Gris



Treteimer 15 L

Pedal bin · Poubelle à pédale

1 - 1

17136 4025457171369

Deckel und Boden aus Kunststoff schwarz
Lid and Stand: PP-Plastic, black
Couvercle et socle: PP-Plastique, noir

Beige · Beige · Beige



Treteimer 15 L

Pedal bin · Poubelle à pédale

1 - 1

17133 4025457171338

Deckel und Boden aus Kunststoff schwarz
Lid and Stand: PP-Plastic, black
Couvercle et socle: PP-Plastique, noir

Rot · Red · Rouge

Toplader

Edelstahl · Stainless steel · Inox

Edelstahl
Stainless steel · Inox



Sensor-Abfalleimer Ramon 30 L

Sensor waste bin · Poubelle sensor

1 - 2

17711 4025457177118

Edelstahl · Stainless steel · Inox

Glänzend · Bright · Brillant

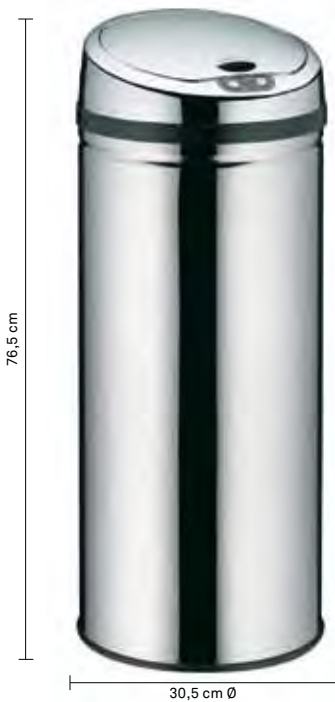

Sensor-Abfalleimer Ramon 42 L

Sensor waste bin · Poubelle sensor

1 - 2

17712 4025457177125

Edelstahl · Stainless steel · Inox

Glänzend · Bright · Brillant



Abfalleimer Pinar 27 L

Waste bin · Poubelle

1 - 1

15824 4025457158247

Edelstahl · Stainless steel · Inox

Matt · Matt · Mat

Deckel ABS-Kunststoff, schwarz
Lid: ABS-Plastic, black
Couvercle: ABS-Plastique, noir

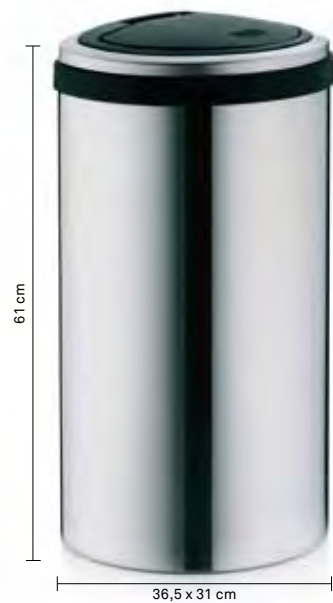

Abfalleimer Pinar 38 L

Waste bin · Poubelle

1 - 1

15822 4025457158223

Edelstahl · Stainless steel · Inox

Matt · Matt · Mat

Deckel ABS-Kunststoff, schwarz
Lid: ABS-Plastic, black
Couvercle: ABS-Plastique, noir

Raumwunder

Edelstahl · Stainless steel · Inox

Edelstahl
Stainless steel · Inox

Treteimer Duo 24 L
Pedal bin · Poubelle à pédale

1 - 1 

21540 4025457215407 

Edelstahl · Stainless steel · Inox

Matt · Matt · Mat

Zwei Kammern á 12 L
Two compartments á 12 L
Deux compartiments de 12 L



Treteimer Selina 20 L
Pedal bin · Poubelle à pédale

1 - 1 

15820 4025457158209 

Edelstahl · Stainless steel · Inox

Matt · Matt · Mat



Treteimer Ida 27 L
Pedal bin · Poubelle à pédale

1 - 1 

15821 4025457158216 

Edelstahl · Stainless steel · Inox

Matt · Matt · Mat



Schwingdeckeleimer Dina 65 L
Bin with swing lid
Poubelle avec couvercle à balance

1 - 1 

11530 4025457115301 

Edelstahl · Stainless steel · Inox

Matt · Matt · Mat

Edelstahl

Edelstahl · Stainless steel · Inox

Edelstahl Stainless steel · Inox	Guarantee 5 Years	Silent Close 
--	---------------------------------------	--



Treteimer Nila 12 L
Pedal bin · Poubelle à pédale

1 - 4 

10925 4025457109256 

Edelstahl · Stainless · Inox

Glänzend · Bright · Brillant



Treteimer Nevia 20 L
Pedal bin · Poubelle à pédale

1 - 2 

10926 4025457109263 

Edelstahl · Stainless · Inox

Glänzend · Bright · Brillant



Treteimer Mala 12 L
Pedal bin · Poubelle à pédale

1 - 4 

10927 4025457109270 

Edelstahl · Stainless · Inox

Matt · Matt · Mat



Treteimer Malik 20 L
Pedal bin · Poubelle à pédale

1 - 2 

10928 4025457109287 

Edelstahl · Stainless · Inox

Matt · Matt · Mat

Pulverbeschichtet

Metall, farbig beschichtet · Metal, colour coated · Métal revêtement couleur



Treteimer Cornell 12 L
Pedal bin · Poubelle à pédale

1 - 4

10929 4025457109294

Metall · Metal · Métal

Matt · Matt · Mat

Wei · White · Blanc



Treteimer Bastian 20 L
Pedal bin · Poubelle à pédale

1 - 2

10930 4025457109300

Metall · Metal · Métal

Matt · Matt · Mat

Wei · White · Blanc



Treteimer Kilian 12 L
Pedal bin · Poubelle à pédale

1 - 4

10931 4025457109317

Metall · Metal · Métal

Matt · Matt · Mat

Schwarz · Black · Noir



Treteimer Joshua 12 L
Pedal bin · Poubelle à pédale

1 - 4

10932 4025457109324

Metall · Metal · Métal

Matt · Matt · Mat

Beige · Beige · Beige



Treteimer Leandro 12 L
Pedal bin · Poubelle à pédale

1 - 4

10933 4025457109331

Metall · Metal · Métal

Matt · Matt · Mat

Hellgrau · Light grey · Gris clair

Paco

Müllbeutel aus HDPE Folie
Trash bag of HDPE-foile
Sacs poubelles HDPE

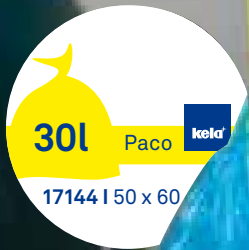

Paco



Müllbeutel 5 L

Trash bag · Sac poubelle

1 - 48 

17148 4025457171482 

HDPE, 14 my

34 x 48 cm

40 Stück · 40 pieces · 40 pièces

Mit Trageschleife · With wrist strap · Avec liens

3 L - 5 L

Treteimer · Pedal bin · Poubelle à pédale

Für alle Kela Standard-Treteimer 3 L + 5 L
For all Kela standard-pedal bins 3 L + 5 L
Pour toutes poubelles Kela standard 3 L + 5 L



Müllbeutel 18 L

Trash bag · Sac poubelle

1 - 24 

17146 4025457171468 

HDPE, 10 my

40 x 50 cm

40 Stück · 40 pieces · 40 pièces

Mit Zugband · With wrist strap · Avec liens

6 L - 10 L

Treteimer · Pedal bin · Poubelle à pédale

Kela 17130, 21540, 22625



Müllbeutel 20 L

Trash bag · Sac poubelle

1 - 24 

17145 4025457171451 

HDPE, 10 my

45 x 55 cm

35 Stück · 35 pieces · 35 pièces

Mit Zugband · With wrist strap · Avec liens

12 L - 18 L

Treteimer · Pedal bin · Poubelle à pédale

Kela 10925, 10927, 10929, 10931, 10932,
10933, 17131, 21452



Müllbeutel 30 L

Trash bag · Sac poubelle

1 - 24 

17144 4025457171444 

HDPE, 10 my

50 x 60 cm

30 Stück · 30 pieces · 30 pièces

Mit Zugband · With wrist strap · Avec liens

20 L - 28 L

Treteimer · Pedal bin · Poubelle à pédale

Kela 10926, 10928, 10930, 11535, 17133,
17136, 17139, 17711



Müllbeutel 60 L

Trash bag · Sac poubelle

1 - 24 

17142 4025457171420 

HDPE, 13 my

60 x 72 cm

13 Stück · 13 pieces · 13 pièces

Mit Zugband · With wrist strap · Avec liens

27 L - 34 L

Treteimer · Pedal bin · Poubelle à pédale

Kela 11536, 11538, 15820, 15821, 15824,
17175, 17180,



Müllbeutel 70 L

Trash bag · Sac poubelle

1 - 24 

17143 4025457171437 

HDPE, 13 my

66 x 85 cm

13 Stück · 13 pieces · 13 pièces

Mit Zugband · With wrist strap · Avec liens

35 L - 45 L

Treteimer · Pedal bin · Poubelle à pédale

Kela 11530, 15822, 17132, 17135, 17138,
17141, 17712

Rimossa

PP-Kunststoff, Innenfutter: Stoff

PP-Plastic, lining: Tissue

PP-Plastique, intérieur: Tissus



Schwarz · Black · Noir



Korb-Set

Basket set · Set corbeilles

1 - 4

32124 4025457321245



3-teilig · 3 pieces · 3 pièces

1x 30 x 22 cm, 20 cm h

1x 36 x 26 cm, 24 cm h

1x 42 x 30 cm, 26 cm h



Korb-Set

Basket set · Set corbeilles

1 - 6

21780 4025457217807



5-teilig · 5 pieces · 5 pièces

2x 20 x 14 cm, 11 cm h

2x 22 x 16 cm, 14 cm h

1x 35 x 25 cm, 15 cm h



Edelstahl
Stainless steel · Inox

Korb

Basket · Corbeilles

- 3* 12

28 x 20 cm, 12 cm h

21850 4025457218507



- 3* 9

31 x 23 cm, 14 cm h

21851 4025457218514



Rimossa

PP-Kunststoff, Innenfutter: Stoff

PP-Plastic, lining: Tissue

PP-Plastique, intérieur: Tissus



Korb-Set

Basket set · Set corbeilles

1 - 4

21672 4025457216725



3-teilig · 3 pieces · 3 pièces

1x 30 x 22 cm, 20 cm h

1x 36 x 26 cm, 24 cm h

1x 42 x 30 cm, 26 cm h



Korb-Set

Basket set · Set corbeilles

1 - 6

21781 4025457217814



5-teilig · 5 pieces · 5 pièces

2x 20 x 14 cm, 11 cm h

2x 22 x 16 cm, 14 cm h

1x 35 x 25 cm, 15 cm h



Weiß · White · Blanc

Edelstahl

Stainless steel · Inox

Korb

Basket · Corbeille

- 3* 12

28 x 20 cm, 12 cm h

21848 4025457218484



- 3* 9

31 x 23 cm, 14 cm h

21849 4025457218491



Korb-Set

Basket set · Set corbeilles

1 - 4

31280 4025457312809



3-teilig · 3 pieces · 3 pièces

1x 30 x 22 cm, 20 cm h

1x 36 x 26 cm, 24 cm h

1x 42 x 30 cm, 26 cm h



Korb-Set

Basket set · Set corbeilles

1 - 6

21783 4025457217838



5-teilig · 5 pieces · 5 pièces

2x 20 x 14 cm, 11 cm h

2x 22 x 16 cm, 14 cm h

1x 35 x 25 cm, 15 cm h



Grau · Grey · Gris

Edelstahl

Stainless steel · Inox

Korb

Basket · Corbeille

- 3* 12

28 x 20 cm, 12 cm h

21842 4025457218422



- 3* 9

31 x 23 cm, 14 cm h

21843 4025457218439



Rimossa

PP-Kunststoff, Innenfutter: Stoff
 PP-Plastic, lining: Tissue
 PP-Plastique, intérieur: Tissus

Brombeer · Blackberry · Mûre



Korb-Set

Basket set · Set corbeilles

1 - 4

32125 4025457321252



3-teilig · 3 pieces · 3 pièces

1x 30 x 22 cm, 20 cm h
 1x 36 x 26 cm, 24 cm h
 1x 42 x 30 cm, 26 cm h



Korb-Set

Basket set · Set corbeilles

1 - 6

21785 4025457217852



5-teilig · 5 pieces · 5 pièces

2x 20 x 14 cm, 11 cm h
 2x 22 x 16 cm, 14 cm h
 1x 35 x 25 cm, 15 cm h



Edelstahl
 Stainless steel · Inox

Korb

Basket · Corbeille

- 3* 12 28 x 20 cm, 12 cm h

21844 4025457218446



- 3* 9 31 x 23 cm, 14 cm h

21845 4025457218453



Blau · Blue · Bleu



Korb-Set

Basket set · Set corbeilles

1 - 4

32196 4025457321962



3-teilig · 3 pieces · 3 pièces

1x 30 x 22 cm, 20 cm h
 1x 36 x 26 cm, 24 cm h
 1x 42 x 30 cm, 26 cm h



Korb-Set

Basket set · Set corbeilles

1 - 6

21786 4025457217869



5-teilig · 5 pieces · 5 pièces

2x 20 x 14 cm, 11 cm h
 2x 22 x 16 cm, 14 cm h
 1x 35 x 25 cm, 15 cm h



Edelstahl
 Stainless steel · Inox

Korb

Basket · Corbeille

- 3* 12 28 x 20 cm, 12 cm h

21846 4025457218460



- 3* 9 31 x 23 cm, 14 cm h

21847 4025457218477



Rimossa

PP-Kunststoff, Innenfutter: Stoff

PP-Plastic, lining: Tissue

PP-Plastique, intérieur: Tissus



Korb-Set

Basket set · Set corbeilles

1 - 4

21795 4025457217951



3-teilig · 3 pieces · 3 pièçes

1x 30 x 22 cm, 20 cm h

1x 36 x 26 cm, 24 cm h

1x 42 x 30 cm, 26 cm h



Korb-Set

Basket set · Set corbeilles

1 - 6

21798 4025457217982



5-teilig · 5 pieces · 5 pièçes

2x 20 x 14 cm, 11 cm h

2x 22 x 16 cm, 14 cm h

1x 35 x 25 cm, 15 cm h



NEW Rot · Red · Rouge

Edelstahl
Stainless steel · Inox

Korb

Basket · Corbeille

- 3* 12 28 x 20 cm, 12 cm h

21796 4025457217968



- 3* 9 31 x 23 cm, 14 cm h

21797 4025457217975



Korb-Set

Basket set · Set corbeilles

1 - 4

31282 4025457312823



3-teilig · 3 pieces · 3 pièçes

1x 30 x 22 cm, 20 cm h

1x 36 x 26 cm, 24 cm h

1x 42 x 30 cm, 26 cm h



Korb-Set

Basket set · Set corbeilles

1 - 6

21782 4025457217821



5-teilig · 5 pieces · 5 pièçes

2x 20 x 14 cm, 11 cm h

2x 22 x 16 cm, 14 cm h

1x 35 x 25 cm, 15 cm h



Braun · Brown · Brun

Edelstahl
Stainless steel · Inox

Korb

Basket · Corbeille

- 3* 12 28 x 20 cm, 12 cm h

21840 4025457218408



- 3* 9 31 x 23 cm, 14 cm h

21841 4025457218415



Canistro

Bambus mit Stoffeinsatz, faltbar, mit Reißverschluss, Ledergriffe
 Bomboo with cloth inside, foldable, with zip, leather handles
 Bambou avec tissu, pliable, fermeture à glissière, anses en cuir

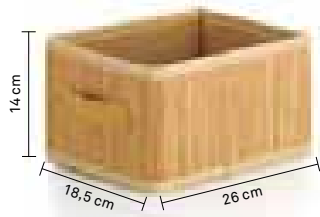

Korb
Basket · Corbeille

1 - 20

22304 4025457223044



Natur · Natural · Naturel



Korb
Basket · Corbeille

1 - 20

22309 4025457223099



Braun · Brown · Brun



Korb
Basket · Corbeille

1 - 20

22307 4025457223075



Grau · Grey · Gris



Korb
Basket · Corbeille

1 - 20

22311 4025457223112



Schwarz · Black · Noir

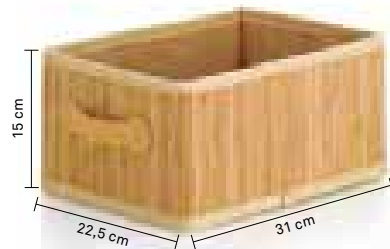

Korb
Basket · Corbeille

1 - 20

22306 4025457223068



Natur · Natural · Naturel



Korb
Basket · Corbeille

1 - 20

22310 4025457223105



Braun · Brown · Brun



Korb
Basket · Corbeille

1 - 30

22308 4025457223082



Grau · Grey · Gris



Korb
Basket · Corbeille

1 - 30

22312 4025457223129



Schwarz · Black · Noir



Textil

- > Dezent und schick oder peppig und bunt - die Kela Textil-Serien bringen Umsatz und Leben auf die Verkaufsfläche.
- >> Subtle, smart design or bright and colourful - our Kela textile series liven up the sales floor and boost your sales.
- >>> Modern, chic, fun ou coloré, toutes les collections textiles animeront votre point de vente.

Amalie

100 % Baumwolle · 100 % Cotton · 100 % Coton



Topfhandschuh

Oven glove · Gant

- 10* 160

10710 4025457107108



Bedruckt · Printed · Imprimé

Topflappen

Oven cloth · Manique

- 10* 180

10712 4025457107122



Bedruckt · Printed · Imprimé



Schürze

Apron · Tablier

- 6* 48

10708 4025457107085



Bedruckt · Printed · Imprimé

Schürze

Apron · Tablier

- 6* 48

10707 4025457107078



Gewebt · Woven · Tissé

Topfhandschuh

Oven glove · Gant

- 10* 160

10709 4025457107092



Gewebt · Woven · Tissé

Topflappen

Oven cloth · Manique

- 10* 180

10711 4025457107115



Gewebt · Woven · Tissé

Amalie

100 % Baumwolle · 100 % Cotton · 100 % Coton

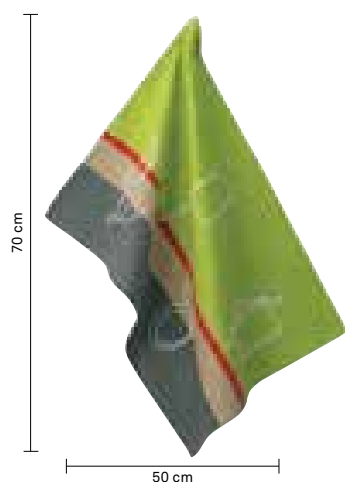

Geschirrtuch

Dish towel · Torchon de cuisine

- 12* 144

10703 4025457107030



Bedruckt · Printed · Imprimé

190 gsm



Geschirrtuch

Dish towel · Torchon de cuisine

- 12* 144

10704 4025457107047



Jacquard · Jacquard · Jacquard

190 gsm



Geschirrtuch

Dish towel · Torchon de cuisine

- 12* 144

10706 4025457107061



Waffelstruktur · Wafer optics · Effet gaufré

Grün · Green · Vert

185 gsm



Geschirrtuch

Dish towel · Torchon de cuisine

- 12* 144

10700 4025457107009



Gewebt · Woven · Tissé

190 gsm



Geschirrtuch

Dish towel · Torchon de cuisine

- 12* 144

10701 4025457107016



10702 4025457107023



Gewebt · Woven · Tissé

190 gsm

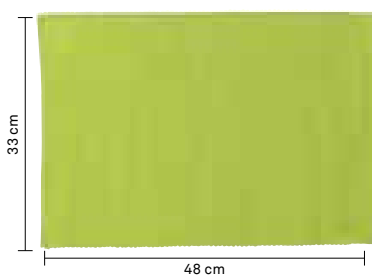

Tisch-Set Pur

Table-set · Set de table

- 12* 120

77796 4025457777967



Grün · Green · Vert

Diego

100 % Baumwolle · 100 % Cotton · 100 % Coton



Schürze Points

Apron · Tablier

- 6* 48

15578 4025457155789 

Bedruckt · Printed · Imprimé

Schürze Stripes

Apron · Tablier

- 6* 48

15584 4025457155840 

Gewebt · Woven · Tissé

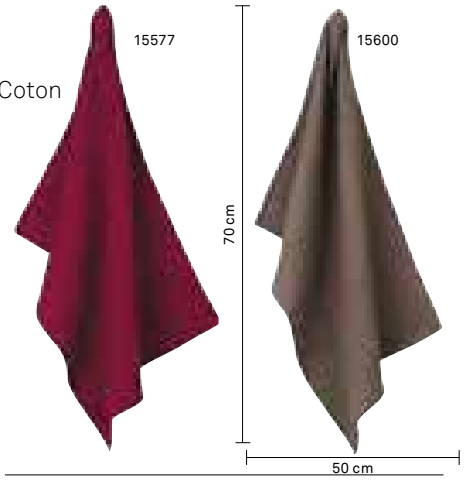

Geschirrtuch

Dish towel · Torchon de cuisine

- 12* 144

15577 4025457155772 

Altrot · Dark red · Rouge ancien

15600 4025457156007 

Taupe · Taupe · Taupe

Waffelstruktur · Wafer optics · Effet gaufré

185 gsm



Geschirrtuch

Dish towel · Torchon de cuisine

- 12* 144

15575 4025457155758 

Bedruckt · Printed · Imprimé

190 gsm



Geschirrtuch

Dish towel · Torchon de cuisine

- 12* 144

15576 4025457155765 

15581 4025457155819 

Gewebt · Woven · Tissé

190 gsm



Geschirrtuch

Dish towel · Torchon de cuisine

- 12* 144

15582 4025457155826 

15583 4025457155833 

Gewebt · Woven · Tissé

190 gsm



Diego

100 % Baumwolle · 100 % Cotton · 100 % Coton



Topfhandschuh Points

Oven glove · Gant

- 10* 160

15580 4025437155802



Bedruckt · Printed · Imprimé



Topflappen Points

Oven cloth · Manique

- 10* 180

15579 4025457155796



Bedruckt · Printed · Imprimé



Tisch-Set Pur

Table-set · Set de table

- 12* 120

77772 4025457777721



Altrot · Dark red · Rouge ancien



Topfhandschuh Stripes

Oven glove · Gant

- 10* 160

15586 4025457155864



Gewebt · Woven · Tissé



Topflappen Stripes

Oven cloth · Manique

- 10* 180

15585 4025457155857



Gewebt · Woven · Tissé



Tisch-Set Pur

Table-set · Set de table

- 12* 120

77789 4025457777899



Taupe · Taupe · Taupe



Edelstahl 18/10

Stainless steel · Inox

Vorratsdose 1,0 L

Storage jar · Boîte hermétique

- 4* 12

15607 4025457156076



Glas, Edelstahldeckel, mit Einleger
Glass, lid stainless steel, with inlay
Verre, couvercle inox, avec feuille déco



Edelstahl 18/10

Stainless steel · Inox

Vorratsdose 1,5 L

Storage jar · Boîte hermétique

- 4* 12

15606 4025457156069



Glas, Edelstahldeckel, mit Einleger
Glass, lid stainless steel, with inlay
Verre, couvercle inox, avec feuille déco



Edelstahl 18/10

Stainless steel · Inox

Vorratsdose 2,0 L

Storage jar · Boîte hermétique

- 4* 12

15605 4025457156052



Glas, Edelstahldeckel, mit Einleger
Glass, lid stainless steel, with inlay
Verre, couvercle inox, avec feuille déco

Doreen

100 % Baumwolle · 100 % Cotton · 100 % Coton



Schürze Stripes

Apron · Tablier

- 6* 48

15590 4025457155901 

Gewebt · Woven · Tissé

Schürze Latte

Apron · Tablier

- 6* 48

15596 4025457155963 

Bedruckt · Printed · Imprimé

Geschirrtuch

Dish towel · Torchon de cuisine

- 12* 144

15589 4025457155895 

Crème · Cream · Crème

15599 4025457155994 

Chocolat · Dark chocolate · Chocolat foncé

Waffelstruktur · Wafer optics · Effet gaufré

185 gsm



15595



15587



15588



15593



15594

Geschirrtuch

Dish towel · Torchon de cuisine

- 12* 144

15595 4025457155956 

Bedruckt · Printed · Imprimé

190 gsm

Geschirrtuch

Dish towel · Torchon de cuisine

- 12* 144

15587 4025457155871 

15588 4025457155888 

Gewebt · Woven · Tissé

190 gsm

Geschirrtuch

Dish towel · Torchon de cuisine

- 12* 144

15593 4025457155932 

15594 4025457155949 

Gewebt · Woven · Tissé

190 gsm

Doreen

100 % Baumwolle · 100 % Cotton · 100 % Coton



Topfhandschuh Latte

Oven glove · Gant

- 10* 160

15598 4025457155987



Bedruckt · Printed · Imprimé



Topflappen Latte

Oven cloth · Manique

- 10* 180

15597 4025457155970



Bedruckt · Printed · Imprimé



Tisch-Set Pur

Table-set · Set de table

- 12* 120

77788 4025457777882



Crème · Cream · Crème



Topfhandschuh Stripes

Oven glove · Gant

- 10* 160

15592 4025457155925



Gewebt · Woven · Tissé



Topflappen Stripes

Oven cloth · Manique

- 10* 180

15591 40254571555918



Gewebt · Woven · Tissé



Tisch-Set Pur

Table-set · Set de table

- 12* 120

77787 4025457777875



Chocolat · Dark chocolate · Chocolat foncé



Edelstahl 18/10
Stainless steel · Inox

Vorratsdose 1,0 L

Storage jar · Boîte hermétiques

- 4* 12

15610 4025457156106



Glas, Edelstahldeckel, mit Einleger
Glass, lid stainless steel, with inlay
Verre, couvercle inox, avec feuille déco



Edelstahl 18/10
Stainless steel · Inox

Vorratsdose 1,5 L

Storage jar · Boîte hermétiques

- 4* 12

15609 4025457156090



Glas, Edelstahldeckel, mit Einleger
Glass, lid stainless steel, with inlay
Verre, couvercle inox, avec feuille déco



Edelstahl 18/10
Stainless steel · Inox

Vorratsdose 2,0 L

Storage jar · Boîte hermétiques

- 4* 12

15608 4025457156083



Glas, Edelstahldeckel, mit Einleger
Glass, lid stainless steel, with inlay
Verre, couvercle inox, avec feuille déco

Franka

100 % Baumwolle · 100 % Cotton · 100 % Coton

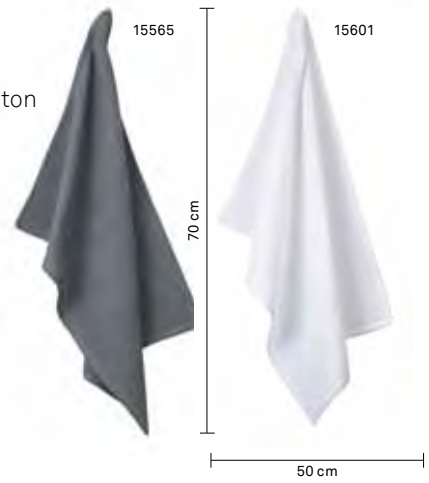
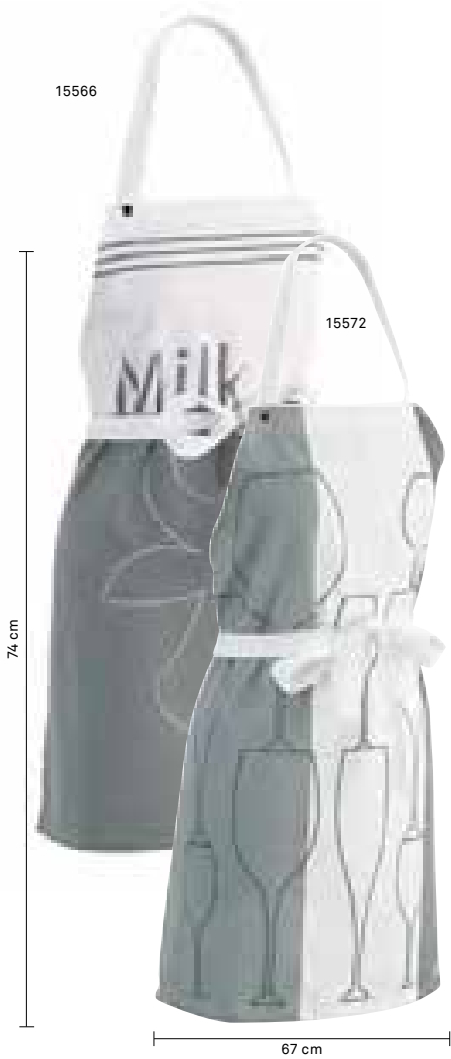

Schürze Milk

Apron · Tablier

- 6* 48

15566 4025457155666 

Bedruckt · Printed · Imprimé

Schürze Glasses

Apron · Tablier

- 6* 48

15572 4025457155727 

Bedruckt · Printed · Imprimé

Geschirrtuch

Dish towel · Torchon de cuisine

- 12* 144

15565 4025457155659 

Grau · Grey · Gris

15601 4025457156014 

Weiß · White · Blanc

Waffelstruktur · Wafer optics · Effet gaufré

185 gsm

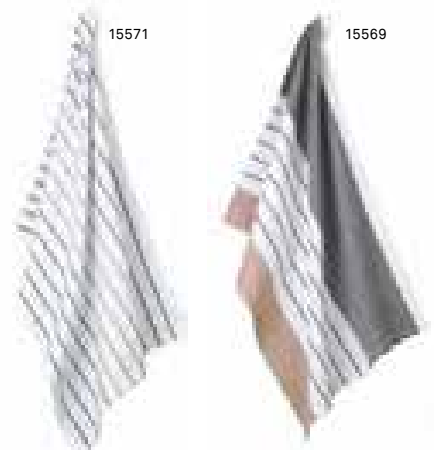

Geschirrtuch

Dish towel · Torchon de cuisine

- 12* 144

15570 4025457155703 

15564 4025457155642 

Bedruckt · Printed · Imprimé

190 gsm

Geschirrtuch

Dish towel · Torchon de cuisine

- 12* 144

15563 4025457155635 

Gewebt · Woven · Tissé

190 gsm

Geschirrtuch

Dish towel · Torchon de cuisine

- 12* 144

15571 4025457155710 

15569 4025457155697 

Gewebt · Woven · Tissé

190 gsm

Franka

100 % Baumwolle · 100 % Cotton · 100 % Coton

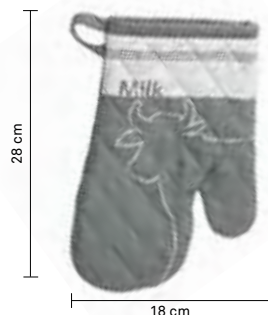

Topfhandschuh Milk

Oven glove · Gant

- 10* 160

15568 4025457155680



Bedruckt · Printed · Imprimé



Topflappen Milk

Oven cloth · Manique

- 10* 180

15567 4025457155673



Bedruckt · Printed · Imprimé



Tisch-Set Pur

Table-set · Set de table

- 12* 120

77786 4025457777868



Frostgrau · Frost grey · Gris



Topfhandschuh Glasses

Oven glove · Gant

- 10* 160

15574 4025457155741



Bedruckt · Printed · Imprimé



Topflappen Glasses

Oven cloth · Manique

- 10* 180

15573 4025457155734



Bedruckt · Printed · Imprimé



Tisch-Set Pur

Table-set · Set de table

- 12* 120

77768 4025457777684



Weiß · White · Blanc



Edelstahl 18/10
Stainless steel · Inox

Vorratsdose 1,0 L

Storage jar · Boîte hermétiques

- 4* 12

15604 4025457156045



Glas, Edelstahldeckel, mit Einleger
Glass, lid stainless steel, with inlay
Verre, couvercle inox, avec feuille déco



Edelstahl 18/10
Stainless steel · Inox

Vorratsdose 1,5 L

Storage jar · Boîte hermétiques

- 4* 12

15603 4025457156038



Glas, Edelstahldeckel, mit Einleger
Glass, lid stainless steel, with inlay
Verre, couvercle inox, avec feuille déco



Edelstahl 18/10
Stainless steel · Inox

Vorratsdose 2,0 L

Storage jar · Boîte hermétiques

- 4* 12

15602 4025457156021



Glas, Edelstahldeckel, mit Einleger
Glass, lid stainless steel, with inlay
Verre, couvercle inox, avec feuille déco

Garden



100 % Baumwolle
100 % Cotton · 100 % Coton

Schürze
Apron · Tablier

- 6* 48

16964 4025457169649

Gewebt · Woven · Tissé

Motiv gestickt
Motif embroidered · Motif brodé



Topfhandschuh
Oven glove · Gant

- 10* 160

16965 4025457169656

Bedruckt · Printed · Imprimé



Topflappen
Oven cloth · Manique

- 10* 180

16966 4025457169663

Bedruckt · Printed · Imprimé

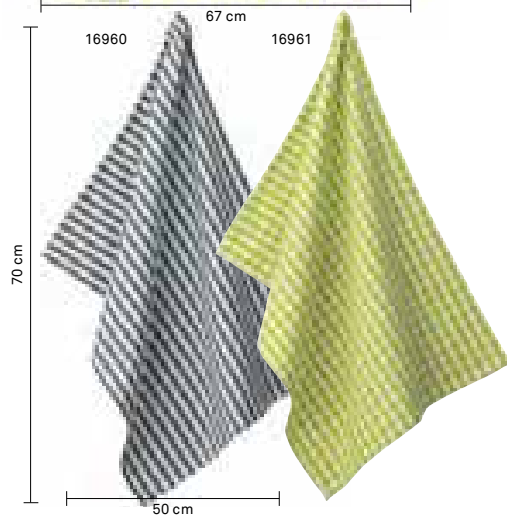

Geschirrtuch

Dish towel · Torchon de cuisine

- 12* 144

16960 4025457169601

16961 4025457169618

Gewebt · Woven · Tissé



Geschirrtuch

Dish towel · Torchon de cuisine

- 12* 144

16962 4025457169625

Jacquard · Jacquard · Jacquard



Geschirrtuch

Dish towel · Torchon de cuisine

- 12* 144

16963 4025457169632

Bedruckt · Printed · Imprimé

BBQ

100 % Baumwolle · 100 % Cotton · 100 % Coton

Schürze

Apron · Tablier

- 6* 48

16991 4025457169915 

Rot · Red · Rouge

16993 4025457169939 

Schwarz · Black · Noir

Gewebt · Woven · Tissé

Motiv gestickt

Motif embroidered · Motif brodé

Topfhandschuh

Oven glove · Gant

- 10* 80

16990 4025457169908 

Rot · Red · Rouge

16992 4025457169922 

Schwarz · Black · Noir

Gewebt · Woven · Tissé

Motiv gestickt, Unterseite hitzebeständig

Motif embroidered, backside heat resistant

Motif brodé, revers résistant à la chaleur



Quality



Einheitsgröße

Der Nackengurt der Küchenschürze ist mit Druckknöpfen versehen. Dadurch lässt sich die Küchenschürze leicht auf verschiedene Größen anpassen.

One size

The neck strap of the kitchen apron has press studs attached. This means that the apron can easily be adjusted to different sizes.

One size

Le passant pour le cou du tablier de cuisine est pourvu de boutons-pression. Ce qui permet d'ajuster facilement le tablier de cuisine à toutes les tailles.

Die Präsentation

Trendorientierte Farbkombinationen - verpackt in die perfekte Präsentationswand. Die Rückwand lässt sich spielend einfach in das flexible Shop in Shop System von Kela einfügen.

The presentation

Trend-focussed colour combinations - packed into the perfect presentation wall. The rear wall can simply be inserted into the flexible shop in shop system of Kela.

La présentation

Des combinaisons de couleurs tendances - présentées sur un panneau de présentation idéal. La partie arrière se laisse très facilement insérer dans le système Shop in Shop flexible de Kela.

Im Detail

Unsere Textilien sind aus 100 % Baumwolle gefertigt, saugfähig und fusselfarm. Besonderer Wert wurde auf die Ausführung im Detail gelegt. Die Ecken sind hochwertig vernäht und an einer Seite mit einer Aufhängung versehen. Ob bedruckt, gewebt oder im Waffelpique - bei dieser exklusiven Designauswahl ist für jeden Geschmack etwas dabei.



Details

Our kitchen textiles are made of 100 % cotton. They are absorbent and low in lint. Particular value is placed on their detailed design. The corners are sewn over the corner to a high quality and have a loop on one side. Whether the design is printed, woven or in waffle cotton, there is something for everyone in this exclusive range of designs.

Dans le détail

Nos textiles de cuisine sont 100 % coton, absorbants et non pelucheux. Une importance particulière a été accordée à l'exécution dans le détail. Les coins font l'objet d'une couture rabattue de qualité supérieure et sont dotés d'une suspension d'un côté. Imprimé, tissé ou alvéolé - ce choix de design exclusif sait répondre à tous les goûts.





Tisch-Sets

> Tisch-Sets perfekt präsentiert.

>> A well thought-out concept. Our table sets are also available in a matching display unit.

>>> Un concept bien pensé. Nos sets de table peuvent également être associés au présentoir correspondant.

Durchdacht

> Tisch-Sets perfekt präsentiert.

>> A well thought-out concept.

Our table sets are also available in a matching display unit.

>>> Un concept bien pensé. Nos sets de table peuvent également être associés au présentoir correspondant.

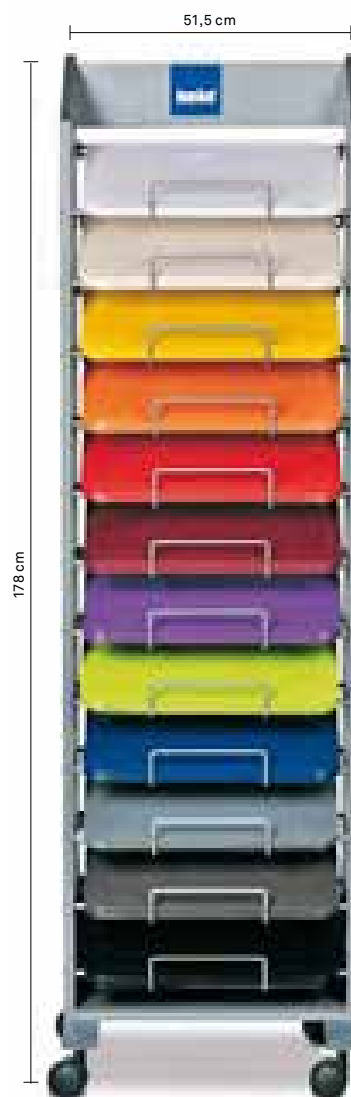
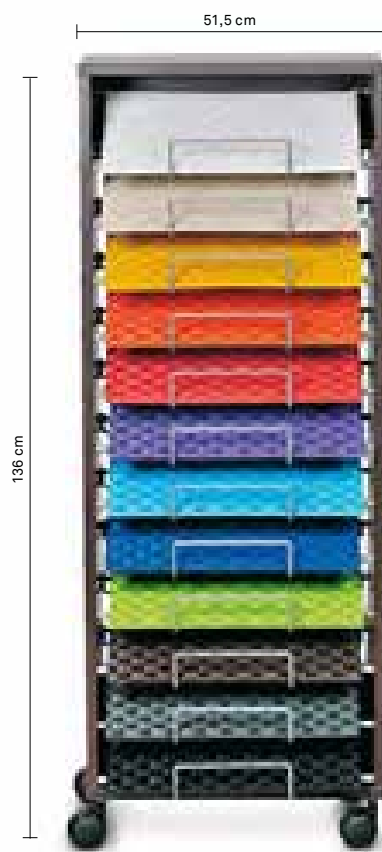

Ados

PP-Kunststoff · PP-Plastic · PP-Plastique

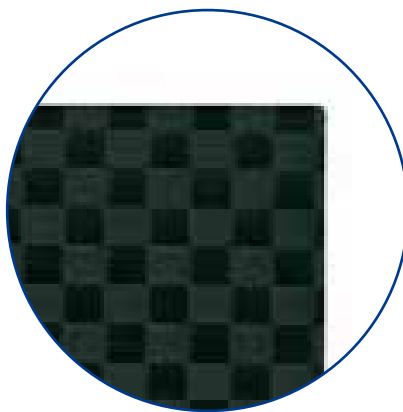

Tisch-Set

Table-set · Set de table

- 12* 96

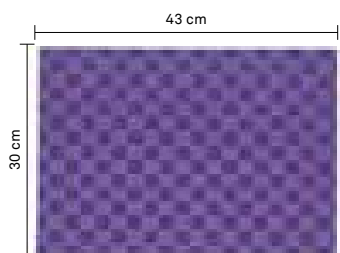

Brombeer · Blackberry · Mûre

10910 4025457109102

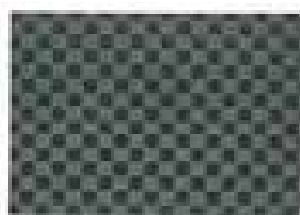

Grau · Grey · Gris

10911 4025457109119

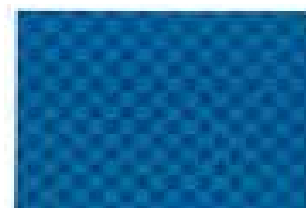

Blau · Blue · Bleu

10912 4025457109126

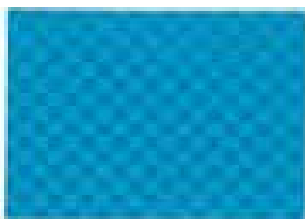

Eisblau · Ice-blue · Bleu glace

10913 4025457109133

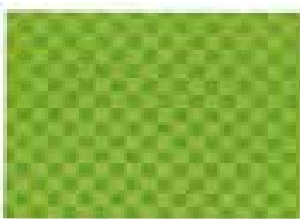

Lemongrün · Lemon green · Vert citron

10914 4025457109140

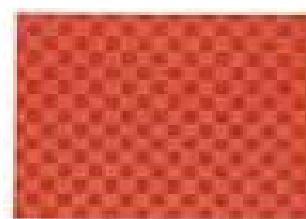

Rot · Red · Rouge

10915 4025457109157

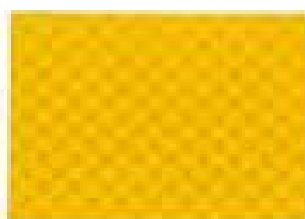

Gelb · Yellow · Jaune

10916 4025457109164

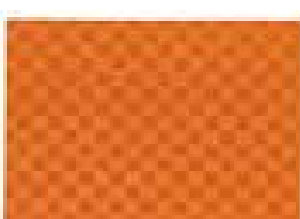

Orange · Orange · Orange

10917 4025457109171



Schwarz · Black · Noir

10918 4025457109188

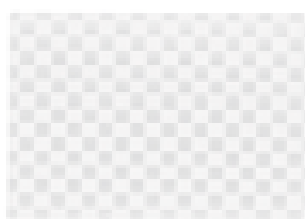

Weiß · White · Blanc

10919 4025457109195

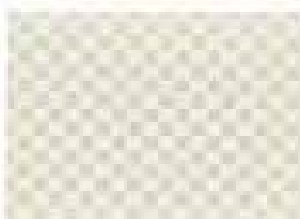

Crème · Cream · Crème

10920 4025457109201



Dunkelbraun · Dark brown · Brun foncé

10921 4025457109218



Neta

100 % PVC · 100 % PVC · 100 % PVC

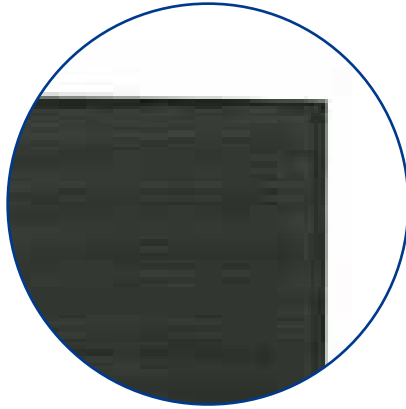

Tisch-Set

Table-set · Set de table

- 12* 72



Feige · Fig · Figue

15615 4025457156151

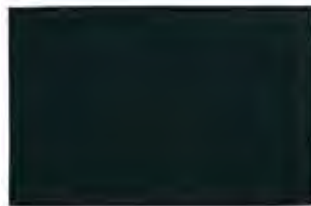

Schwarz · Black · Noir

15611 4025457156113



Anthrazit · Anthracite · Anthracite

15612 4025457156120



Olive · Olive · Olive

15616 4025457156168

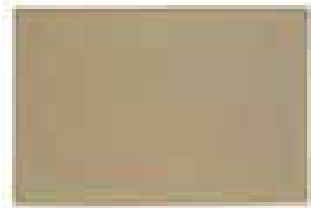

Beige · Beige · Beige

15613 4025457156137



Elfenbein · Ivory · Ivoire

15617 4025457156175



Brombeer · Blackberry · Mûre

15620 4025457156205



Schwarz · Black · Noir

15621 4025457156212

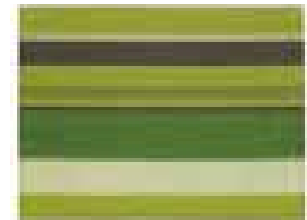

Grün · Green · Vert

15622 4025457156229



Grün · Green · Vert

15630 4025457156304

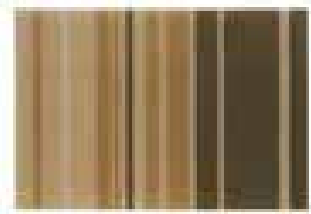

Beige · Beige · Beige

15631 4025457156311

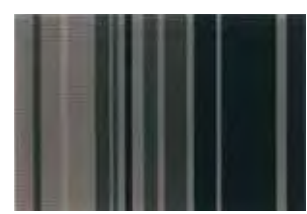

Grau · Grey · Gris

15632 4025457156328



Plato

Polyvinyl / 70 % PVC / 30 % Polyester
 Polyvinyl / 70 % PVC / 30 % Polyester
 Polyvinyle / 70% PVC / 30 % Polyester

Tisch-Set

Table-set · Set de table

- 12* 96

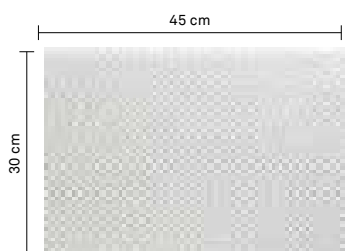
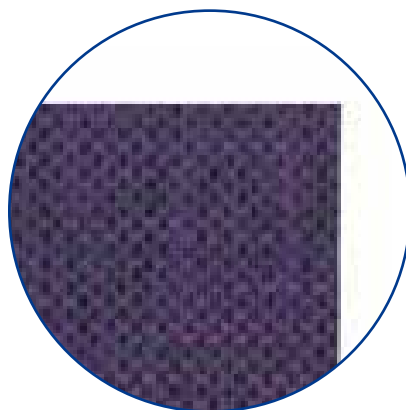

Weiß · White · Blanc

15633 4025457156335



Crème · Cream · Crème

15634 4025457156342



Brombeer · Blackberry · Mûre

15635 4025457156359



Brombeer/Schwarz
 Blackberry/Black · Mûre/Noir

15636 4025457156366

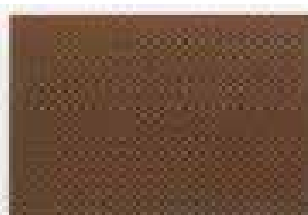

Hellbraun
 Light brown · Brun clair

15637 4025457156373

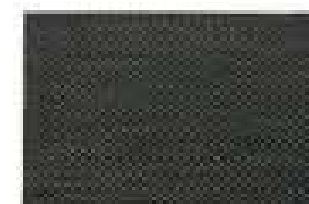

Hellbraun/Schwarz
 Light-brown/Black · Brun clair/Noir

15638 4025457156380



Dunkelbraun · Dark brown · Brun foncé

15639 4025457156397

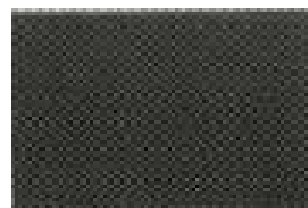

Dunkelbraun/Schwarz
 Dark brown/Black · Brun foncé/Noir

15640 4025457156403



Grau · Grey · Gris

15641 4025457156410

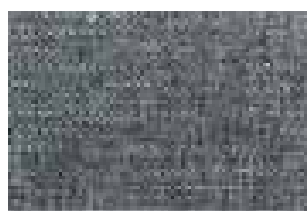

Schwarz/Weiß · Black/White · Noir/Blanc

15644 4025457156441



Grau/Schwarz · Grey/Black · Gris/Noir

15642 4025457156427



Schwarz · Black · Noir

15643 4025457156434



Uni

100 % PVC · 100 % PVC · 100 % PVC

Tisch-Set

Table-set · Set de table

- 12* 144



Eisblau · Ice-blue · Bleu glace

15000 4025457150005



Schwarz · Black · Noir

15007 4025457150074



Weiß · White · Blanc

15006 4025457150067



Beige · Beige · Beige

15008 4025457150081



Gelb · Yellow · Jaune

15002 4025457150029



Orange · Orange · Orange

15003 4025457150036



Rot · Red · Rouge

15001 4025457150012



Altrot · Dark red · Rouge ancien

15014 4025457150142



Dunkelbraun · Dark brown · Brun foncé

15015 4025457150159



Grau · Grey · Gris

15017 4025457150173



Dunkelblau · Dark blue · Bleu foncé

15011 4025457150111



Pink · Pink · Rose

15005 4025457150050



Brombeer · Blackberry · Mûre

15016 4025457150166



Lemongrün · Lemon green · Citron vert

15004 4025457150043



Cado

100 % PVC · 100 % PVC · 100 % PVC

Tisch-Set

Table-set · Set de table

- 12* 108

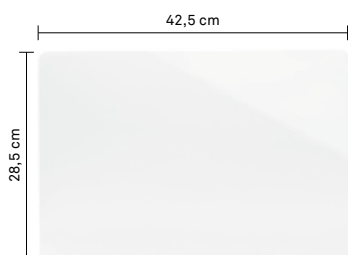

Transparent · Transparent · Transparent

10885 4025457108853



Weiß · White · Blanc

10886 4025457108860



Grau · Grey · Gris

10895 4025457108952

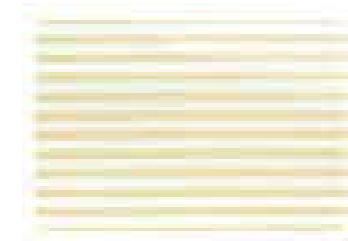

Beige · Beige · Beige

10887 4025457108877

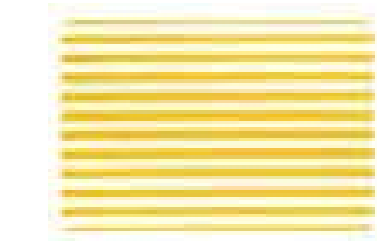

Gelb · Yellow · Jaune

10888 4025457108884

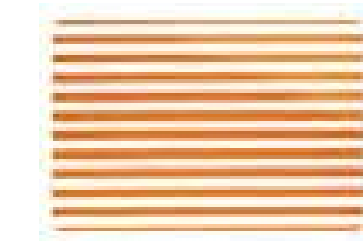

Orange · Orange · Orange

10889 4025457108891

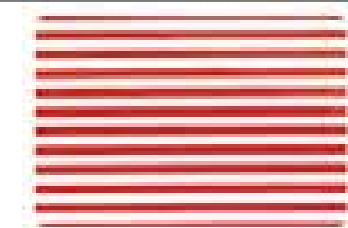

Rot · Red · Rouge

10891 4025457108914

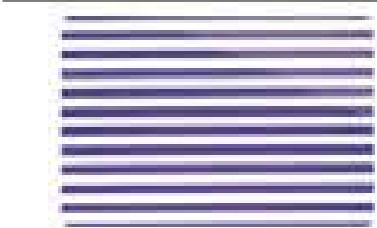

Lila · Purple · Lilas

10892 4025457108921

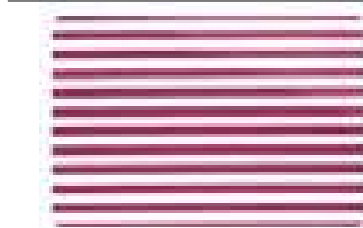

Brombeer · Blackberry · Mûre

10893 4025457108938

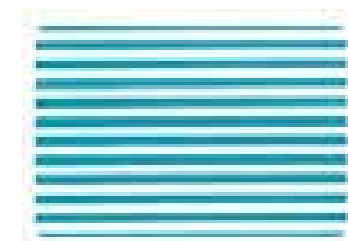

Blau · Blue · Bleu

10894 4025457108945

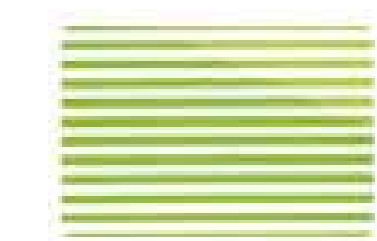

Grün · Green · Vert

10890 4025457108907

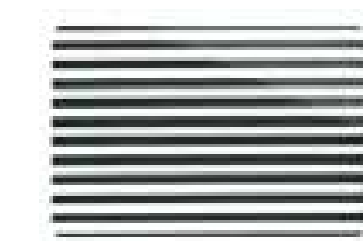

Schwarz · Black · Noir

10896 4025457108969



Picture

PP-Kunststoff · PP-Plastic · PP-Plastique

Tisch-Set

Table-set · Set de table

- 12* 144

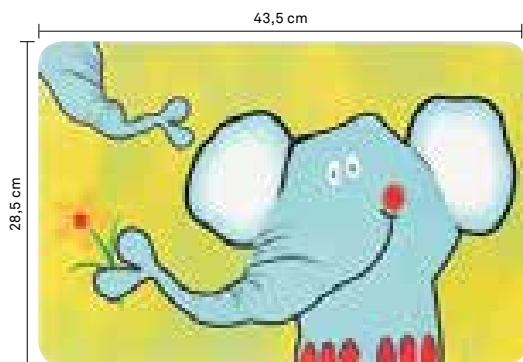

Elephant

15060 4025457150609



Klara

15061 4025457150616

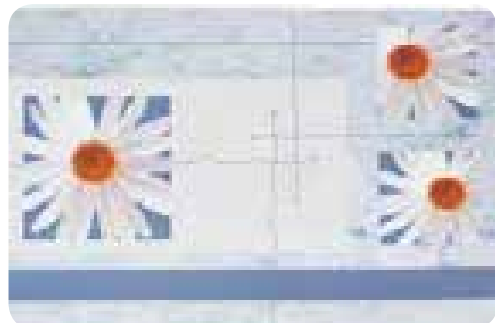

Flower

15081 4025457150814



Gerbera

15056 4025457150562



Coffee + Sugar

15076 4025457150760



Coffee beans

15077 4025457150777



Picture

PP-Kunststoff · PP-Plastic · PP-Plastique

Tisch-Set

Table-set · Set de table

- 12* 144

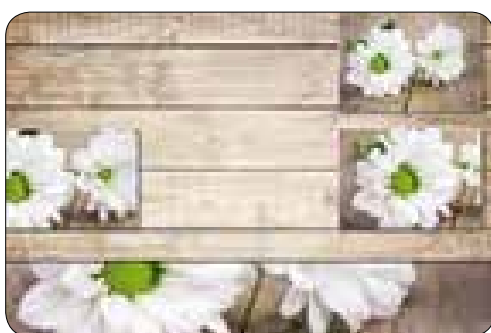

Margarite

15037 4025457150371



Orange juice

15078 4025457150784



Flower red

15039 4025457150395

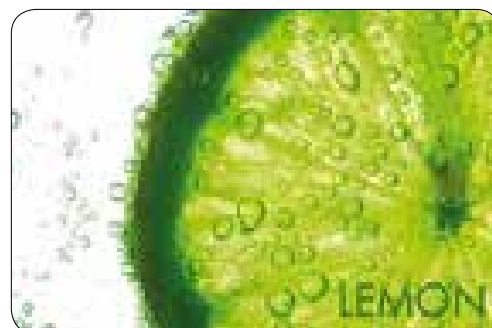

Lemon

15038 4025457150388



Olive

15036 4025457150364

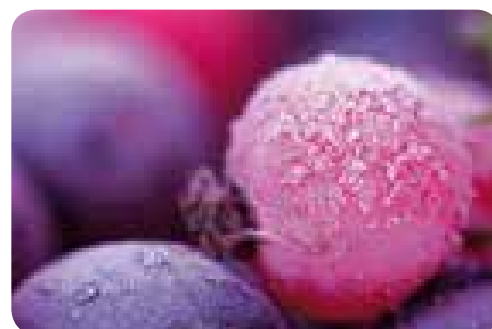

Berry

15035 4025457150357



Pur

100 % Baumwolle · 100 % Cotton · 100 % Cotton

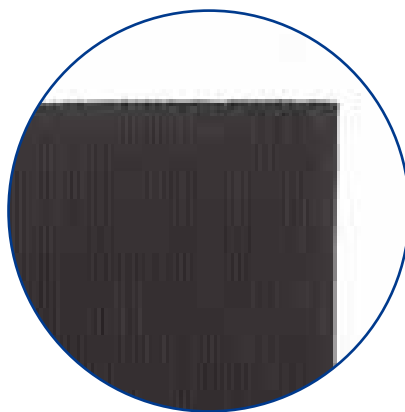

Tisch-Set

Table-set · Set de table

- 12* 120

33 cm x 48 cm



Schokobraun · Chocolate · Chocolat

77815 4025457778155



Chocolat · Dark Chocolate · Chocolat foncé

77787 4025457777875



Dunkelbraun · Dark brown · Brun foncé

77771 4025457777714



Schwarz · Black · Noir

77769 4025457777691



Weiß · White · Blanc

77768 4025457777684



Champagner · Champagne · Champagne

77775 4025457777752



Taupe · Taupe · Taupe

77789 4025457777899



Creme · Cream · Crème

77788 4025457777882



Beige · Beige · Beige

77770 4025457777707



Orange · Orange · Orange

77767 4025457777677



Kürbis · Pumpkin · Citrouille

77774 4025457777745



Rot · Red · Rouge

77765 4025457777653



Altrot · Dark red · Rouge ancien

77772 4025457777721



Sonnengelb · Yellow · Jaune

77793 4025457777936



Eisblau · Ice-blue · Bleu glace

77761 4025457777615



Pur

100 % Baumwolle · 100 % Cotton · 100 % Cotton

Tisch-Set

Table-set · Set de table

- 12* 120

48 cm x 33 cm



Dunkelblau · Dark blue · Bleu foncé

77791 4025457777912



Frostgrau · Frost grey · Gris

77786 4025457777868



Blattgrün · Leaf green · Vert feuille

77824 4025457778247



Grün · Green · Vert

77796 4025457777967



Lemongrün · Lemon green · Citron vert

77764 4025457777646

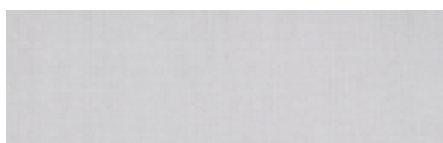

Hellgrau · Light grey · Gris clair

77792 4025457777929



Fuchsia · Fuchsia · Fuchsia

77819 4025457778193



Brombeer · Blackberry · Mûre

77790 4025457777905

Tischläufer

Table runner · Chemin de table

- 6* 30

130 cm x 45 cm



Altrot · Dark red · Rouge ancien

77809 4025457778094



Rot · Red · Rouge

77803 4025457778032



Champagner · Champagne · Champagne

77812 4025457778124



Dunkelbraun · Dark brown · Brun foncé

77808 4025457778087



Schwarz · Black · Noir

77807 4025457778070



Weiß · White · Blanc

77806 4025457778063



Lemongrün · Lemon green · Citron vert

77802 4025457778025

Casa

100 % Bambus · 100 % Bamboo · 100 % Bambou

Tisch-Set

Table-set · Set de table

- 12* 36

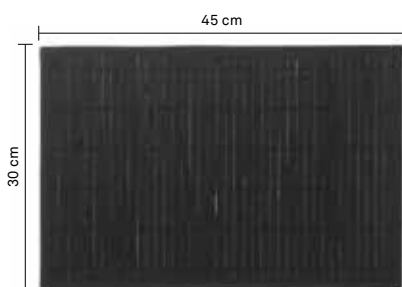
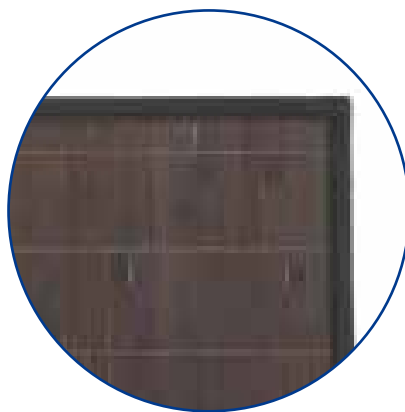

Schwarz · Black · Noir

15520 4025457155208



Beige · Beige · Beige

15517 4025457155178



Natur · Natural · Naturel

15518 4025457155185



Dunkelbraun · Dark brown · Brun foncé

15519 4025457155192





Petit

- > Mit unserer neuen Appetizer-Serie wird Servieren zur wahren Freude.
- > Serving becomes a real pleasure with our new Appetizer range.
- >>> La nouvelle collection Appetizer, un plaisir pour les yeux et les papilles.

Petit Servieren

> Mit unserer neuen Appetizer-Serie wird Servieren zur wahren Freude.
 > Serving becomes a real pleasure with our new Appetizer range.
 >>> La nouvelle collection Appetizer, un plaisir pour les yeux et les papilles.



Dessert-Glas Set

Glass cup set · Verrines

1 8 16 

10981 4025457109812 

4 Stück · 4 pieces · 4 pièces

Glas · Glass · Verre

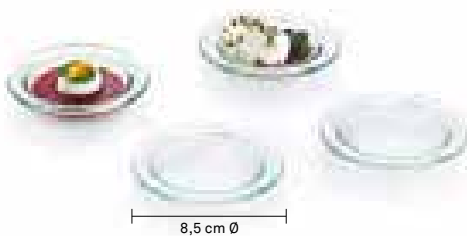

Dessert-Schälchen Set

Glass dishes - Set coupelles en verre

1 12 36 

10979 4025457109799 

4 Stück · 4 pieces · 4 pièces

Glas · Glass · Verre



Dessert-Glas Set

Glass cup set · Verrines

1 12 36 

10980 4025457109805 

4 Stück · 4 pieces · 4 pièces

Glas · Glass · Verre

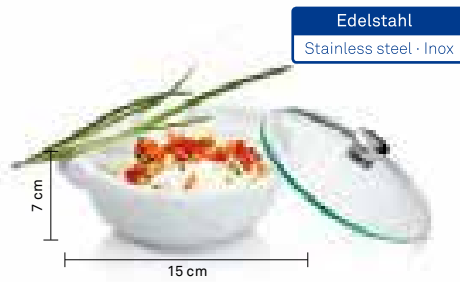

Schälchen
Bowl · Coupelle

1 4 32

10753 4025457107535

Porzellan, Glasdeckel, Edelstahlknopf
Porcelain, glass lid, stainless steel knob
Porcelaine, couvercle en verre, inox



Appetizer-Set

Appetizer-set · Set Amuses bouche

1 - 12

10740 4025457107405

5-teilig · 5 pieces · 5 pièces

Porzellan · Porcelain · Porcelaine

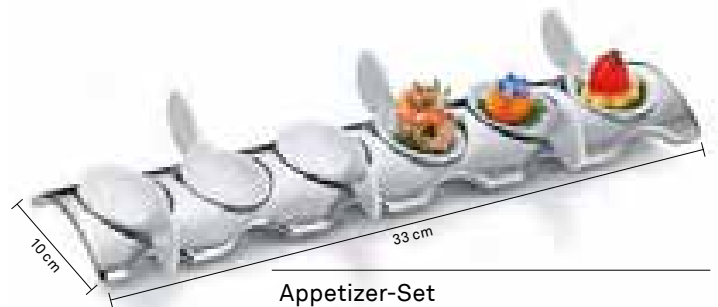

Appetizer-Set

Appetizer-set · Set Amuses bouche

1 - 16

10739 4025457107399

7-teilig · 7 pieces · 7 pièces

Porzellan · Porcelain · Porcelaine



Appetizer-Set

Appetizer-set · Set Amuses bouche

1 - 6

10736 4025457107368

13-teilig · 13 pieces · 13 pièces

Porzellan, Edelstahlöffel
Porcelain, stainless steel spoons
Porcelaine, cuillères en acier 18/10



Petit *Servieren*

> Mit unserer neuen Appetizer-Serie wird Servieren zur wahren Freude.
 > Serving becomes a real pleasure with our new Appetizer range.
 >>> La nouvelle collection Appetizer, un plaisir pour les yeux et les papilles.

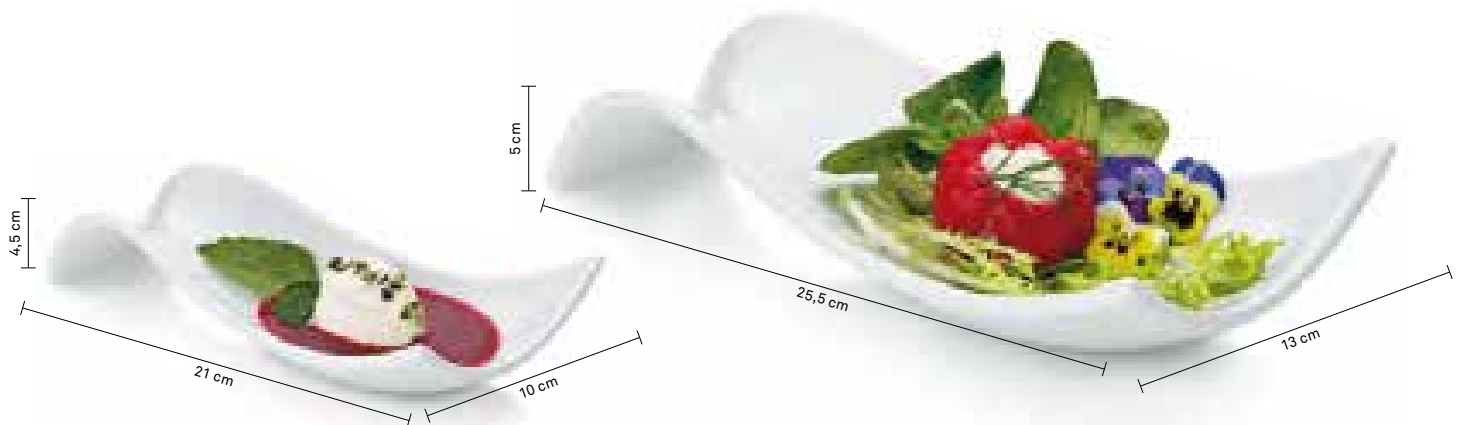

Servierschalen-Set

Bowl-set · Assiette à dessert

1 - 6

10748 4025457107481

2 Stück · 2 pieces · 2 pièces

Porzellan · Porcelain · Porcelaine

Servierschalen-Set

Bowl-set · Assiette à dessert

1 - 6

10760 4025457107603

2 Stück · 2 pieces · 2 pièces

Porzellan · Porcelain · Porcelaine



Salatschüssel

Salad bowl · Saladier

1 - 6

10749 4025457107498

Porzellan · Porcelain · Porcelaine

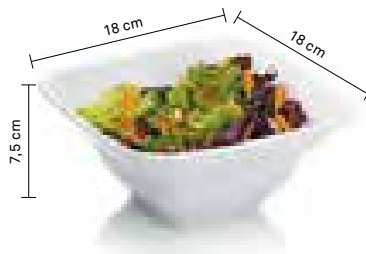

Salatschüssel

Salad bowl · Saladier

1 - 16

10761 4025457107610

Porzellan · Porcelain · Porcelaine

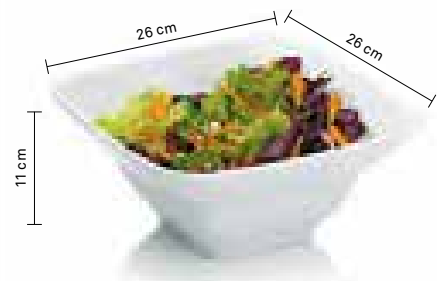

Salatschüssel

Salad bowl · Saladier

1 - 6

10762 4025457107627

Porzellan · Porcelain · Porcelaine

Edelstahl
Stainless steel · Inox



Appetizer-Set

Appetizer-set · Set Amuses bouche

1 - 6

10977 4025457109775

17-teilig · 17 pieces · 17 pièces

Porzellan, Glas, Edelstahl, Schiefer
Porcelain, glass, stainless steel, slate
Porcelaine, verre, inox, ardoise



Amuse Löffel-Set

Spoon-set · Cuillères Amuses bouche

1 12 36

10986 4025457109867

4 Stück · 4 pieces · 4 pièces

Porzellan · Porcelain · Porcelaine



Schälchen-Set

Bowl-set · Coupelles Amuses bouche

1 - 12

10742 4025457107429

4 Stück · 4 pieces · 4 pièces

Porzellan · Porcelain · Porcelaine



Appetizer-Set

Appetizer-set · Set Amuses bouche

1 - 10

10975 4025457109751

7-teilig · 7 pieces · 7 pièces

Porzellan, Schiefer
Porcelain, slate · Porcelaine, ardoise



Dessert-Schälchen-Set

Dessert-bowls · Coupelles à dessert

1 6 12

10987 4025457109874

2 Stück · 2 pieces · 2 pièces

Porzellan · Porcelain · Porcelaine

Petit Anrichten

> Mit unserer neuen Appetizer-Serie wird Servieren zur wahren Freude.
 > Serving becomes a real pleasure with our new Appetizer range.
 >>> La nouvelle collection Appetizer, un plaisir pour les yeux et les papilles.

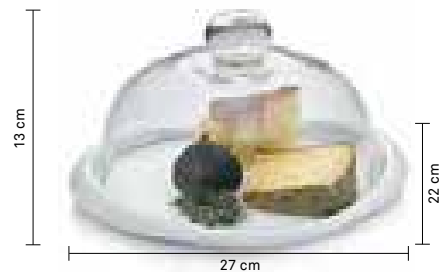

Etagere
 Etagere · Etagère

1 - 6

10745 4025457107450

Porzellan, Metall verchromt
 Porcelain, metal chromed
 Porcelaine, métal chromé

Käseglocke
 Cheese cover · Cloche à fromage

1 - 8

10746 4025457107467

Porzellan, Glasdeckel
 Porcelain, glass lid
 Porcelaine, couvercle en verre

Käseglocke
 Cheese cover · Cloche à fromage

1 - 4

10747 4025457107474

Porzellan, Glasdeckel
 Porcelain, glass lid
 Porcelaine, couvercle en verre



Appetizer-Set

Appetizer-set · Set Amuses bouche

1 - 6

10743 4025457107436

7-teilig · 7 pieces · 7 pièces

Porzellan, Bambus
Porcelain, bamboo
Porcelaine, bambou

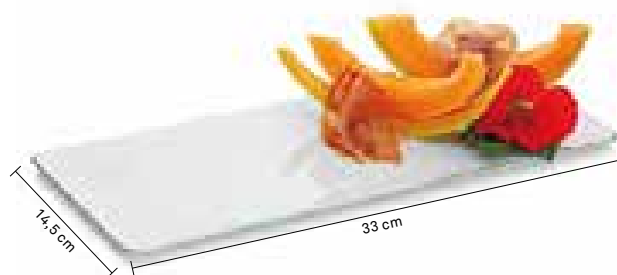

Platte

Plate · Plat

1 - 14

10754 4025457107542

Porzellan · Porcelain · Porcelaine

Silberrand · Silver ring · Filet platine



Dip-Set

Dip set · Set à dip

1 - 12

10741 4025457107412

Porzellan · Porcelain · Porcelaine

Silberrand · Silver ring · Filet platine



Schalen-Trio

Bowl-trio · Coupelles

1 - 18

10752 4025457107528

Porzellan · Porcelain · Porcelaine

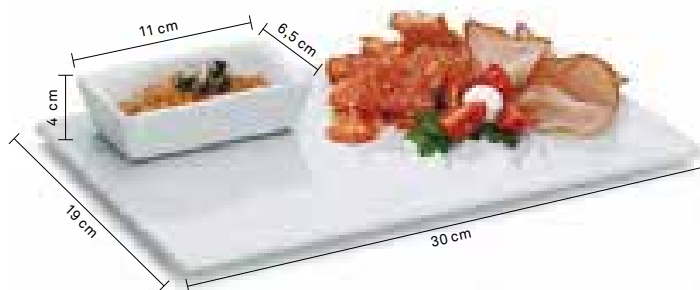

Appetizer-Set

Appetizer-set · Set Amuses bouche

1 - 8

10744 4025457107443

2-teilig · 2 pieces · 2 pièces

Porzellan · Porcelain · Porcelaine

Raffiniert

> Doppelwandiges Schokofondue. Das Wasserbad verhindert ein Anbrennen der Schokolade.

>> Double-walled chocolate fondue. The water quench avoids to scorch the chocolate.

>>> Fondue à double paroi. Le chocolat ne brûle pas grâce au chauffage par bain-marie.



91090



91055

Schokofondue-Set Amarum 400 ml

Chocolate fondue-set · Set fondue à chocolat

1 - 6

16425 4025457164255

7-teilig · 7 pieces · 7 pièces

Ohne Teelicht

Whithout tealight

Sans bougie chauffe-plat

a Keramik · Ceramics · Céramique

b Edelstahl · Stainless steel · Inox

c Kunststoff · Plastic · Plastique

d Metall verchromt

Metal chromed · Métal chromé



Schokofondue-Set Candis 400 ml

Chocolate fondue-set · Set fondue à chocolat

1 - 8

16426 4025457164262

7-teilig · 7 pieces · 7 pièces

Ohne Teelicht

Whithout tealight

Sans bougie chauffe-plat

a Keramik · Ceramics · Céramique

b Edelstahl · Stainless steel · Inox

c Kunststoff · Plastic · Plastique

d Metall verchromt

Metal chromed · Métal chromé



Schokoträume

Schokoladenfondues ohne Teelicht

Chocolate fondue-set without tealight

Set fondue à chocolat sans bougie chauffe-plat



Schokofondue-Set Praliné 250 ml

Chocolate fondue-set · Set fondue à chocolat

1 - 6

663984025457663987

7-teilig · 7 pieces · 7 pièces

a Keramik · Ceramics · Céramique

b Edelstahl · Stainless steel · Inox

c Kunststoff · Plastic · Plastique



Schokofondue-Set Sweety 125 ml

Chocolate fondue-set · Set fondue à chocolat

1 - 6

664084025457664083

5-teilig · 5 pieces · 5 pièces

a Keramik · Ceramics · Céramique

b Edelstahl · Stainless steel · Inox

c Kunststoff · Plastic · Plastique



Schokofondue-Set Choco 400 ml

Chocolate fondue-set · Set fondue à chocolat

1 - 6

663884025457663888

7-teilig · 7 pieces · 7 pièces

a Keramik · Ceramics · Céramique

b Edelstahl · Stainless steel · Inox

c Kunststoff · Plastic · Plastique

d Metall verchromt

Metal chromed · Métal chromé



Blob

Schokoladenfondues ohne Teelicht
 Chocolate fondue-set without tealight
 Set fondue à chocolat sans bougie chauffe-plat



Fondueschälchen-Set

Set fondue bowls · Set coupelles à fondue

1 - 24

664884025457664885

3 Stück · 3 pieces · 3 pièces

Keramik · Ceramics · Céramique



Schokofondue-Set 125 ml

Chocolate fondue-set · Set fondue à chocolat

1 - 24

664864025457664861

3-teilig · 3 pieces · 3 pièces

a Keramik · Ceramics · Céramique

b Edelstahl · Stainless steel · Inox

c Kunststoff · Plastic · Plastique

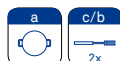

Schokofondue-Set 300 ml

Chocolate fondue-set · Set fondue à chocolat

1 - 12

664874025457664878

7-teilig · 7 pieces · 7 pièces

a Keramik · Ceramics · Céramique

b Edelstahl · Stainless steel · Inox

c Kunststoff · Plastic · Plastique

d Metall verchromt

Metal chromed · Métal chromé



Schokofondues

Schokoladenfondues ohne Teelicht

Chocolate fondue-set without tealight

Set fondue à chocolat sans bougie chauffe-plat



Schokofondue-Set Dolce 250 ml

Chocolate fondue-set · Set fondue à chocolat

1 - 6

66475 4025457664755

8-teilig · 8 pieces · 8 pièces

a Keramik · Ceramics · Céramique

b Edelstahl · Stainless steel · Inox

c Kunststoff · Plastic · Plastique

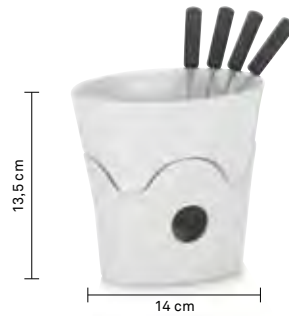

Schokofondue-Set Ola 300 ml

Chocolate fondue-set · Set fondue à chocolat

1 - 12

66480 4025457664809

6-teilig · 6 pieces · 6 pièces

a Porzellan · Porcelain · Porcelaine

b Edelstahl · Stainless steel · Inox

c Kunststoff · Plastic · Plastique



Schokofondue-Set Prado 200 ml

Chocolate fondue-set · Set fondue à chocolat

1 - 12

66431 4025457664311

8-teilig · 8 pieces · 8 pièces

a Keramik · Ceramics · Céramique

b Edelstahl · Stainless steel · Inox

c Kunststoff · Plastic · Plastique

d Metall verchromt

Metal chromed · Métal chromé

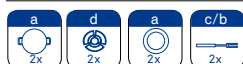

Schokofondue-Set Tondre 200 ml

Chocolate fondue-set · Set fondue à chocolat

1 - 12

66430 4025457664304

8-teilig · 8 pieces · 8 pièces

a Keramik · Ceramics · Céramique

b Edelstahl · Stainless steel · Inox

c Kunststoff · Plastic · Plastique

d Metall verchromt

Metal chromed · Métal chromé

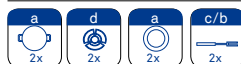

Edelstahl 18/10
Stainless steel · Inox



Schokofonduegabeln Sweet

Chocolate fondue forks

Fourchettes à fondue à chocolat

1 12 72

79194 4025457791949

4 Stück · 4 pieces · 4 pièces

18/10 Edelstahl · Stainless steel · Inox

Kunststoff · Plastic · Plastique



Kochen mit Freunden

> Ob Fondue oder Raclette: Mit dem abgerundeten Sortiment von Kela sind Sie gut beraten.

>> Whether you prefer fondue or raclette: the comprehensive Kela product range is the perfect choice.

>>> Par la diversité de son assortiment, vous trouverez toujours chez Kela le meilleur choix dans le thème de la fondue ou de la raclette.

Käsefondues



> Ein Käsefondue hat nicht nur für die Schweizer Tradition, ist es doch lecker, gemütlich und gesellig. Und so für lange Winterabende mit Freunden oder Familie einfach perfekt.

>> A cheese fondue is not just a Swiss tradition, but a delicious, cosy and companionable way to enjoy a meal. Simply perfect for long winter evenings with friends or family.

>>> La fondue au fromage ne fait pas seulement partie de la tradition suisse, il s'agit également d'un plat convivial, agréable et délicieux. Tout simplement parfait pour les longues soirées d'hiver entre amis ou

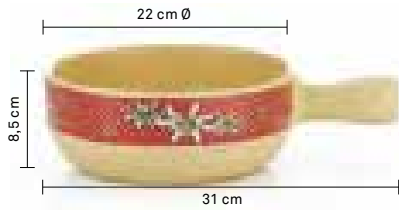

Käsefonduepfanne Friburg 1 L

Cheese fondue pan
Caquelons à fondue à fromage

1 - 1

66503 4025457665035

Feuerfeste Keramik
Oven-Ceramics · Céramique incombustible

Beige · Beige · Beige



Käsefonduepfanne Piemont 1 L

Cheese fondue pan
Caquelons à fondue à fromage

1 - 1

66505 4025457665059

Feuerfeste Keramik
Oven-Ceramics · Céramique incombustible

Beige · Beige · Beige



Käsefonduepfanne Wallis 1 L

Cheese fondue pan
Caquelons à fondue à fromage

1 - 1

66567 4025457665677

Feuerfeste Keramik
Oven-Ceramics · Céramique incombustible

Beige · Beige · Beige



Käsefondue-Set Martigny 1 L

Cheese fondue-set
Service à fondue à fromage

1 - 1

66525 4025457665257

10-teilig · 10 pieces · 10 pièces

a Feuerfeste Keramik
Oven-Ceramics · Céramique incombustible

b Metall · Metal · Métal

c Holz · Wood · Bois

d Kunststoff · Plastic · Plastique

e 18/10 Edelstahl · Stainless steel · Inox



Käsefondue-Set Aosta 1 L

Cheese fondue-set
Service à fondue à fromage

1 - 1

66526 4025457665264

10-teilig · 10 pieces · 10 pièces

a Feuerfeste Keramik
Oven-Ceramics · Céramique incombustible

b Metall · Metal · Métal

c Holz · Wood · Bois

d Kunststoff · Plastic · Plastique

e 18/10 Edelstahl · Stainless steel · Inox



Käsefondue-Set Zermatt 1 L

Cheese fondue-set
Service à fondue à fromage

1 - 1

66601 4025457666018

10-teilig · 10 pieces · 10 pièces

a Feuerfeste Keramik
Oven-Ceramics · Céramique incombustible

b 18/10 Edelstahl · Stainless steel · Inox

c Metall · Metal · Métal

d Kunststoff · Plastic · Plastique



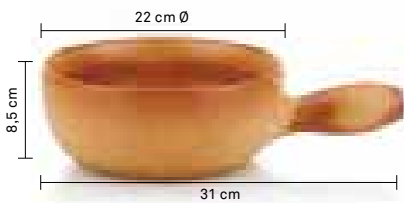

Käsefonduepfanne Davos 1 L
 Cheese fondue pan
 Caquelons à fondue à fromage

1 - 1

66573 4025457665738

Feuerfeste Keramik
 Oven-Ceramics · Céramique incombustible

Beige · Beige · Beige



Käsefonduepfanne Uri 1 L
 Cheese fondue pan
 Caquelons à fondue à fromage

1 - 1

66582 4025457665820

Feuerfeste Keramik
 Oven-Ceramics · Céramique incombustible

Rot · Red · Rouge



Käsefonduepfanne Basel 1 L
 Cheese fondue pan
 Caquelons à fondue à fromage

1 - 1

66575 4025457665752

Feuerfeste Keramik
 Oven-Ceramics · Céramique incombustible

Schwarz · Black · Noir



Käsefondue-Set Tessin 1 L
 Cheese fondue-set
 Service à fondue à fromage

1 - 1

61305 4025457613050

10-teilig · 10 pieces · 10 pièces

a Feuerfeste Keramik
 Oven-Ceramics · Céramique incombustible

b 18/10 Edelstahl · Stainless steel · Inox

c Metall · Metal · Métal

d Kunststoff · Plastic · Plastique



Käsefondue-Set Bern 1 L
 Cheese fondue-set
 Service à fondue à fromage

1 - 1

61303 4025457613036

10-teilig · 10 pieces · 10 pièces

a Feuerfeste Keramik
 Oven-Ceramics · Céramique incombustible

b 18/10 Edelstahl · Stainless steel · Inox

c Metall verchromt

Metal chromed · Métal chromé

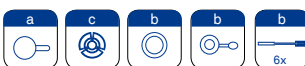

Käsefondue-Set Natura 1 L
 Cheese fondue-set
 Service à fondue à fromage

1 - 1

61306 4025457613067

10-teilig · 10 pieces · 10 pièces

a Feuerfeste Keramik
 Oven-Ceramics · Céramique incombustible

b 18/10 Edelstahl · Stainless steel · Inox

c Metall verchromt

Metal chromed · Métal chromé

d Buche · Beech · Hêtre



Zubehör

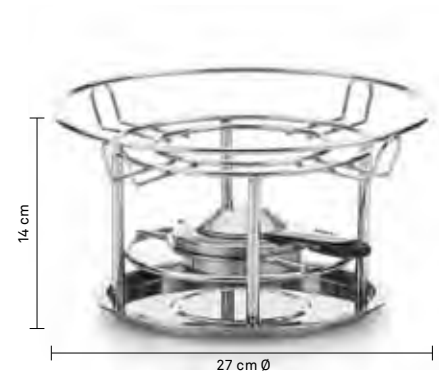

Rechaud Big

Rechaud · Réchaud

1 - 8

61001 4025457610011

3-teilig · 3 pieces · 3 pièces

a 18/10 Edelstahl · Stainless steel · Inox

b Metall verchromt

Metal chromed · Métal chromé



Rechaud Maxi

Rechaud · Réchaud

1 - 12

60127 4025457601279

3-teilig · 3 pieces · 3 pièces

a 18/10 Edelstahl · Stainless steel · Inox

b Metall verchromt

Metal chromed · Métal chromé



Rechaud Rustica

Rechaud · Réchaud

1 - 12

60290 4025457602900

3-teilig · 3 pieces · 3 pièces

a 18/10 Edelstahl · Stainless steel · Inox

b Metall - Metal - Métal

c Holz - Wood - Bois

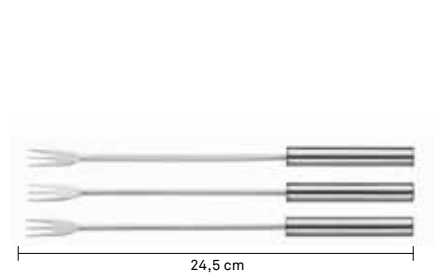
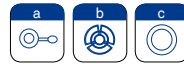

24,5 cm

Edelstahl 18/10
Stainless steel · Inox

Käsefonduegabeln Belana

Cheese fondue forks

Fourchettes à fondue a fromage

1 12 48

79186 4025457791864

6 Stück · 6 pieces · 6 pièces

18/10 Edelstahl · Stainless steel · Inox



24,5 cm

Edelstahl 18/10
Stainless steel · Inox

Käsefonduegabeln Morena

Cheese fondue forks

Fourchettes à fondue a fromage

1 12 48

79314 4025457793141

6 Stück · 6 pieces · 6 pièces

18/10 Edelstahl · Stainless steel · Inox

Kunststoff · Plastic · Plastique



15,5 cm Ø

Flammenverteiler

Heat regulating plate · Répartiteur de chaleur

1 - 250

66595 4025457665950

Aluminium · Aluminium · Aluminium

Verteilt die Hitze gleichmäßig auf dem Boden der Käsefonduepfanne und verhindert somit das Anbrennen.

Distributes the heat evenly, to avoid the burning of the cheese.

Réparti la chaleur sous le caquelon de fondue à fromage pour une cuisson uniforme.

Heißer Stein Gourmet

Hot Stone · Pierre Chaude

1 - 2 

66510 4025457665103 

6-teilig · 6 pieces · 6 pièces

CE / GS / CE 350 W

a Stein · Stone · Planche en pierre

b Edelstahl · Stainless steel · Inox

c Metall verchromt

Metal chromed · Métal chromé

d 18/10 Edelstahl · Stainless steel · Inox

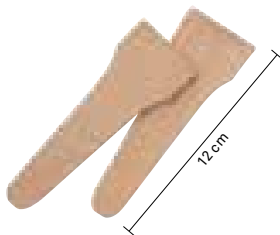
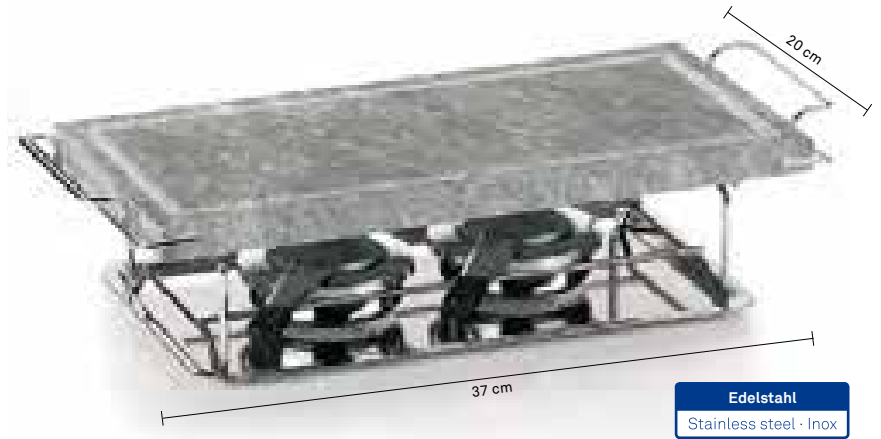
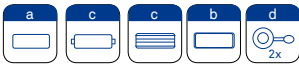

Raclettespatel Arbon

Raclette spatula · Spatules à raclette

1 - 120 

77033 4025457770333 

8-teilig · 8 pieces · 8 pièces

Holz · Wood · Bois

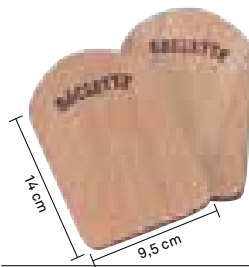

Raclette-Brettchen Baar

Raclette boards · Planchettes à raclette

1 - 48 

77937 4025457779374 

4-teilig · 4 pieces · 4 pièces

Holz · Wood · Bois

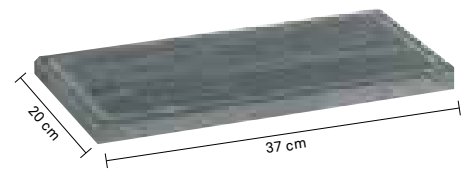

Grillstein

Hot Stone · Pierre Chaude

1 - 3

66513 4025457665134 

Passend zu · Suitable for · Adaptable pour **66510**

Edelstahl 18/10
Stainless steel · Inox



Pastenbrenner-Set Vesuv

Paste burner-set · Set brûleur à pâte

1 - 24 

63067 4025457630675 

2-teilig · 2 pieces · 2 pièces

18/10 Edelstahl · Stainless steel · Inox

Brennpaste · Combustible paste · Pâte à brûler

UN 1170



Brennpasten-Set Magma

Combustible paste set · Set pâte à brûler

1 - 24 

63018 4025457630187 

3-teilig · 3 pieces · 3 pièces

3 x 80 g

UN 1170



Brennpastenflasche Liquid 1,0 L

Bottle with combustible paste

Bouteille combustible liquide

- 12*

63054 4025457630545 

1,0 L / 800 g

UN 1193



Feuerzangen- bowle Heinz Rühmann

Feuerzangenbowle
Heinz Rühmann 3,5 L
Fire tongs punch · Punch

1 - 1 

66160 4025457661600 

15-teilig · 15 pieces · 15 pièces

- a Feuerfestes Glas · Oven proof glass
Verre résistant au feu
- b Edelstahl · Stainless steel · Inox
- c Metall verchromt
Metal chromed · Métal chromé
- d SAN-Kunststoff · SAN-Plastic · SAN-Plastique
- e 18/10 Edelstahl · Stainless steel · Inox

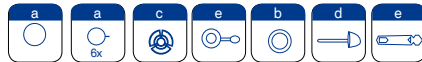

Edelstahl 18/10
Stainless steel · Inox

Zuckerzange

Sugar tongue · Pince à sucre

1 - 120 

65147 4025457651472 

18/10 Edelstahl · Stainless steel · Inox



Punsch-Set

Punsch-Set Saffira 5,2 L

Punch-set · Set Punch

1 - 1 

66180 4025457661808 

9-teilig · 9 pieces · 9 pièces

a Feuerfestes Glas · Oven proof glass
Verre résistant au feu

b SAN-Kunststoff · SAN-Plastic · SAN-Plastique



Sommerbowle

Feuerfestes Glas · Oven proof glass · Verre résistant au feu

Sommerbowle Livina 3,5 L
Summer punch bowl · Pot à punch

1 - 1 

66175 4025457661754 

8-teilig · 8 pièces · 8 pièces

a Feuerfestes Glas · Oven proof glass
Verre résistant au feu

b SAN-Kunststoff · SAN-Plastic · SAN-Plastique



Gläser und Zubehör

Hitzebeständig · Heat resistant · Résistant à la chaleur



Glasbecher-Set Orion 300 ml
Punch glasses · Mug à punch

1 - 6

10756 4025457107566

Glas · Glass · Verre

4-teilig · 4 pieces · 4 pièces



Bowleglas-Set 250 ml
Punch glasses · Set verre à punch

1 - 6

10757 4025457107573

Glas · Glass · Verre

4-teilig · 4 pieces · 4 pièces

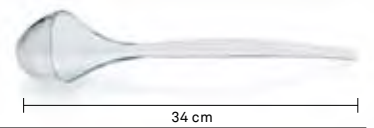

Bowlelöffel
Punch bowl ladle · Cuillère à punch

1 - 250

65149 4025457651496

SAN-Kunststoff · SAN-Plastic · SAN-Plastique

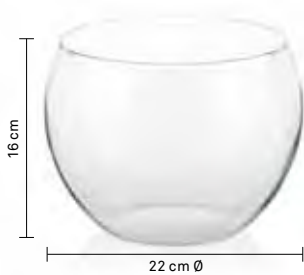

Bowletopf 3,5 L
Punch bowl · Pot à punch

1 - 1

66164 4025457661648

Glas · Glass · Verre



Bowletopf 5,2 L
Punch bowl · Pot à punch

1 - 1

66172 4025457661723

Glas · Glass · Verre

4-teilig · 4 pieces · 4 pièces



Glasdeckel zu 66172
Glass lid for punch bowl
Couvercle pour pot à punch

1 - 1

66173 4025457661730

Astana



> Besonders niederes Fonduekarussell für perfekten Zugriff und gute
Einsicht – Sicherheit durch Standfestigkeit.

>> Especially low fondue carousel for a perfect access – safety due to stability.

>>> Carrousel à fondue avec coupelles particulièrement basses pour une
parfaite maniabilité – socle très stable qui assure la sécurité.



Fonduekarussell 1,7 L

Fondue carrousel · Carrousel à fondue

1 - 2

10775 4025457107757

23-teilig · 23 pieces · 23 pièces

a 18/10 Edelstahl · Stainless steel · Inox

b Edelstahl · Stainless steel · Inox

c Metall verchromt

Metal chromed · Métal chromé

d Keramik · Ceramics · Céramique

e Holz · Wood · Bois



Lormes

> Das Fonduekarussell Lormes verbindet auf elegante Weise fernöstliche und heimische Fondue-Kultur: Durch schlichtes Design in den Farbtönen Schwarz, Weiß und Edelstahl verbindet Lormes Purismus mit Eleganz.

>> Fondue carousel Lormes is an elegant combination of Oriental and Western fondue culture: With its unassuming design in black, white and stainless steel, Lormes combines purism with elegance.

>>> Le carrousel à fondue Lormes, mariage entre élégance et culture de la fondue. Son design simple dans les tons noir, blanc et acier le rend épuré.



Fonduekarussell 1,2 L

Fondue carrousel · Carrousel à fondue

1 - 2

664054025457664052

23-teilig · 23 pieces · 23 pièces

a 18/10 Edelstahl · Stainless steel · Inox

b Edelstahl · Stainless steel · Inox

c Metall verchromt
Metal chromed · Métal chromé

d Keramik · Ceramic · Céramique

e Holz · Wood · Bois

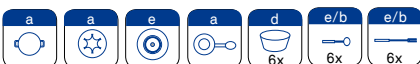

Livorno/Lugano



Fonduekarussell Livorno 1,2 L
Fondue carrousel · Carrousel à fondue

1 - 3

66370 4025457663703

22-teilig · 22 pieces · 22 pièces

- a 18/10 Edelstahl · Stainless steel · Inox
- b Edelstahl · Stainless steel · Inox
- c Metall verchromt
Metal chromed · Métal chromé
- d Keramik · Ceramics · Céramique
- e Kunststoff · Plastic · Plastique

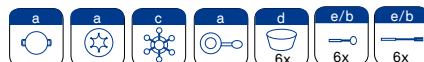

Fonduekarussell Lugano 1,2 L
Fondue carrousel · Carrousel à fondue

1 - 3

61203 4025457612039

22-teilig · 22 pieces · 22 pièces

- a Emailliert · Enamelled · Emaillé
- b Edelstahl · Stainless steel · Inox
- c Metall verchromt
Metal chromed · Métal chromé
- d Keramik · Ceramics · Céramique
- e Kunststoff · Plastic · Plastique
- f 18/10 Edelstahl · Stainless steel · Inox

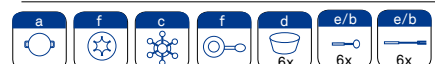

Stockholm/Siena/Cailin



Fondue-Set Stockholm 1,4 L

Fondue-set · Service à fondue

1 - 4

664494025457664496

11-teilig · 11 pieces · 11 pièces

- a 18/10 Edelstahl · Stainless steel · Inox
- b Edelstahl · Stainless steel · Inox
- c Metall verchromt
Metal chromed · Métal chromé
- d Kunststoff · Plastic · Plastique



Fondue-Set Siena 1,2 L

Fondue-set · Service à fondue

1 - 6

663864025457663864

11-teilig · 11 pieces · 11 pièces

- a Emailliert · Enamelled · Emaillé
- b Edelstahl · Stainless steel · Inox
- c Metall verchromt
Metal chromed · Métal chromé
- d Kunststoff · Plastic · Plastique
- e 18/10 Edelstahl · Stainless steel · Inox



Fondue-Set Cailin

Fondue-set · Service à fondue

1 - 4

109684025457109683

10-teilig · 10 pieces · 10 pièces

- a 18/10 Edelstahl · Stainless steel · Inox
- b Edelstahl · Stainless steel · Inox



Armata

> Bei den Fondues Armata sind hochwertige Materialien, wie Edelstahl 18/10 und Akazienholz, geschmackvoll kombiniert.

>> Our Armata fondues offer a tasteful combination of high-quality materials such as stainless steel 18/10 and acacia wood.

>>> Les carrousels à fondue Armata combinent des matériaux de grande qualité comme l'acier inoxydable 18/10 et le bois d'acacia.

66452



30 Seite · Page · Page



Edelstahl 18/10
Stainless steel · Inox

Fonduekarussell 1,2 L

Fondue carrousel · Carrousel à fondue

1 - 2

664704025457664700

23-teilig · 23 pieces · 23 pièces

a 18/10 Edelstahl · Stainless steel · Inox

b Edelstahl · Stainless steel · Inox

c Metall verchromt

Metal chromed · Métal chromé

d Keramik · Ceramics · Céramique

e Akazie · Acacia · Acacia

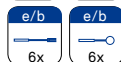

Edelstahl 18/10
Stainless steel · Inox

Fondue-Set 1,2 L

Fondue-set · Service à fondue

1 - 4

664064025457664069

11-teilig · 11 pieces · 11 pièces

a 18/10 Edelstahl · Stainless steel · Inox

b Edelstahl · Stainless steel · Inox

c Metall verchromt

Metal chromed · Métal chromé

d Akazie · Acacia · Acacia



Natura

> Rustikal und gemütlich. Die Serie Natura bringt - durch das Buchenholz - Hüttenflair in die eigenen vier Wände.

>> Rustic and cosy. The beechwood of the Natura range brings the flair of an Alpine log cabin into your own four walls.

>>> Rustique et conviviale. Avec son bois de hêtre, la série Natura confère à votre intérieur une ambiance conviviale de chalet.



Fonduekarussell

Fondue carrousel · Carrousel à fondue

1 - 1

61201 4025457612015

23-teilig · 23 pieces · 23 pièces

- a Emailliert · Enamelled · Émaillé
- b 18/10 Edelstahl · Stainless steel · Inox
- c Edelstahl · Stainless steel · Inox
- d Metall verchromt
Metal chromed · Métal chromé
- e Keramik · Ceramics · Céramique
- f Buche · Beech · Hêtre

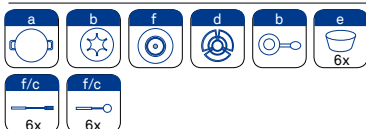

Käsefondue-Set

Cheese fondue-set

Service à fondue à fromage

1 - 1

61306 4025457613067

10-teilig · 10 pieces · 10 pièces

- a Feuerfeste Keramik · Oven-Ceramics
Céramique incombustible
- b Edelstahl · Stainless steel · Inox
- c Metall verchromt
Metal chromed · Métal chromé
- d Buche · Beech · Hêtre
- e 18/10 Edelstahl · Stainless steel · Inox

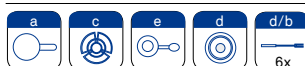

Rechaud

Rechaud · Réchaud

1 - 12

61000 4025457610004

3-teilig · 3 pieces · 3 pièces

- a 18/10 Edelstahl · Stainless steel · Inox
- b Metall verchromt
Metal chromed · Métal chromé
- c Buche · Beech · Hêtre

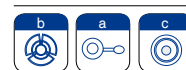



Zubehör

18/10 Edelstahl · Stainless steel · Inox

Edelstahl 18/10
Stainless steel · Inox

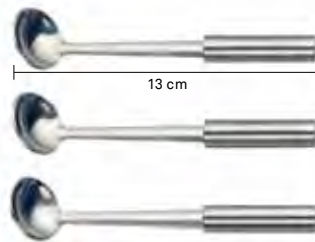

Fondueöffel-Set Belana

Fondue spoon set · Cuillères à fondue

1 12 48

79185 4025457791857

6 Stück · 6 pieces · 6 pièces

18/10 Edelstahl · Stainless steel · Inox



Fondueöffel-Set Morena

Fondue spoon set · Cuillères à fondue

1 12 48

79312 4025457793127

6 Stück · 6 pieces · 6 pièces

18/10 Edelstahl · Stainless steel · Inox

Kunststoff · Plastic · Plastique

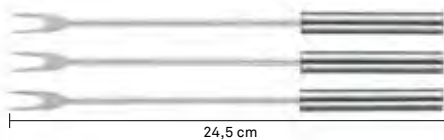

Fonduegabel-Set Belana

Fondue fork set · Fourchettes à fondue

1 12 48

79184 4025457791840

6 Stück · 6 pieces · 6 pièces

18/10 Edelstahl · Stainless steel · Inox

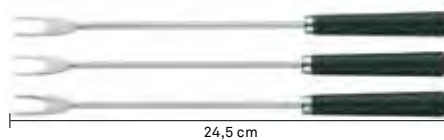

Fonduegabel-Set Morena

Fondue fork set · Fourchettes à fondue

1 12 48

79313 4025457793134

6 Stück · 6 pieces · 6 pièces

18/10 Edelstahl · Stainless steel · Inox

Kunststoff · Plastic · Plastique

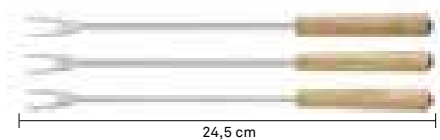

Fonduegabel-Set Modessa

Fondue fork set · Fourchettes à fondue

1 12 48

79164 4025457791642

6 Stück · 6 pieces · 6 pièces

18/10 Edelstahl · Stainless steel · Inox

Esche · Ash · Frêne

Fondueteller

Keramik · Ceramics · Céramique



23 cm Ø

Fondueteller Chalet

Fondue plate · Assiette à fondue

1 6 12

67327 4025457673276



Weiß glänzend · White bright · Blanc brillant



26 cm Ø

Fondueteller Arcade

Fondue plate · Assiette à fondue

1 6 12

67837 4025457678370



Weiß glänzend · White bright · Blanc brillant



20 cm

28 cm

Fondueteller Oval

Fondue plate · Assiette à fondue

1 6 12

67401 4025457674013



Weiß glänzend · White bright · Blanc brillant



Fondueteller Chalet

Fondue plate · Assiette à fondue

1 6 12

67320 4025457673207



Schwarz matt · Black matt · Noir mat



Fondueteller Arcade

Fondue plate · Assiette à fondue

1 6 12

67838 4025457678387



Schwarz matt · Black matt · Noir mat



Fondueteller Oval

Fondue plate · Assiette à fondue

1 6 12

67400 4025457674006



Schwarz matt · Black matt · Noir mat



5,5 cm

12 cm Ø

Fondueschälchen Chalet

Fondue bowl · Coupelle à fondue

- 4* 72

67451 4025457674518



Weiß glänzend · White bright · Blanc brillant



Fondueschälchen Chalet

Fondue bowl · Coupelle à fondue

- 4* 72

67450 4025457674501



Schwarz matt · Black matt · Noir mat

Allgemeine Verkaufs- und Lieferbedingungen der Keck & Lang GmbH

1. Allgemeines, Geltungsbereich

1. Das Angebot, Bestellungen zu tätigen, richtet sich ausschließlich an gewerbliche Kunden. Mit seiner Bestellung bestätigt der Besteller, dass alle mit uns abgeschlossenen Rechtsgeschäfte seiner gewerblichen oder selbständigen beruflichen Tätigkeit zuzurechnen sind.

2. Wir erbringen unsere Lieferungen und Leistungen ausschließlich aufgrund der nachstehenden allgemeinen Geschäftsbedingungen. Abweichenden Bedingungen des Vertragspartners wird hiermit ausdrücklich widersprochen.

3. Es besteht Einigkeit, dass diese allgemeinen Geschäftsbedingungen auch für weitere Aufträge gelten, ohne dass hierauf nochmals besonders Bezug genommen werden muss.

4. Abweichende oder ergänzende Vereinbarungen haben nur dann Gültigkeit, wenn sie schriftlich abgeschlossen oder von uns schriftlich bestätigt sind.

2. Zustandekommen des Vertrages

1. Alle in unserem Katalog dargestellten Leistungen stellen lediglich eine Aufforderung an den Besteller dar, ein Angebot abzugeben. Wir behalten uns die Annahme eines solchen Angebots vor. Ein Vertrag kommt erst mit der Bestätigung durch uns zustande. Die Bestätigung kann per Brief, Telefax, E-Mail oder auch schlüssig durch Ausführung des Auftrages erfolgen.

3. Preise

1. Unsere Preise verstehen sich zuzüglich der jeweiligen gesetzlichen Mehrwertsteuer. Sie gelten ab Werk und schließen deshalb Kosten für Fracht, Porto und Versicherung sowie sonstige Versandkosten nicht ein. Ab einem Mindestwert, den wir Ihnen auf Anfrage beziffern, liefern wir frei Haus.

4. Lieferungen, Gefahrenübergang

1. Teillieferungen sind zulässig und verpflichten den Besteller zur Zahlung der anteiligen Vergütung, es sei denn, dass die Entgegennahme der Teillieferung unzumutbar wäre. Jede Teillieferung gilt als Erledigung eines gesonderten Auftrages im Sinne dieser Bedingungen.

2. Lieferungen erfolgen ab Werk auf Kosten des Bestellers. Die Gefahr für die Ware geht mit ihrem Verlassen der Rampe beim Herstellerwerk oder mit Mitteilung der Versandbereitschaft auf den Besteller über. Dies gilt auch bei Teillieferungen und dann, wenn wir Versandkosten oder Anfuhr der Ware übernommen haben.

3. Die Waren werden demontiert geliefert, soweit es die Versandart und das Transportrisiko erfordern.

4. Der Abschluss einer Transport- oder sonstigen Versicherung erfolgt nur auf ausdrücklichen Wunsch und auf Kosten des Bestellers.

5. Bei Abnahmeverzug trägt der Besteller die bei uns angefallenen Lagerkosten. Diese betragen für jede volle Woche der Verspätung ein halbes Prozent, insgesamt aber maximal 5% vom Nettowert der nicht abgenommenen Ware. Dem Besteller bleibt es vorbehalten,

einen geringeren und uns bleibt es vorbehalten, einen höheren Schaden nachzuweisen. Wir sind berechtigt, nach Ablauf einer von uns gesetzten angemessenen Abnahmefrist über den Liefergegenstand anderweitig zu verfügen und den Besteller mit angemessen verlängerten Fristen zu beliefern.

5. Lieferfristen und -termine

1. Die von uns angegebenen Lieferfristen sind freibleibend und nur angenähert, es sei denn, es wurden ausdrücklich einzelvertraglich Fixgeschäfte vereinbart. Sie sind erst maßgeblich, wenn wir von unseren Kunden sämtliche für die Ausführung des Auftrages erforderlichen Unterlagen, Genehmigungen, Freigaben sowie vereinbarte Zahlungen fristgerecht erhalten haben.

2. Die Lieferzeit beginnt frühestens mit dem Eingang unserer Auftragsbestätigung beim Besteller. Sie ist eingehalten, wenn innerhalb der Frist der Liefergegenstand die Rampe im Herstellerwerk verlassen hat, oder die Versandbereitschaft mitgeteilt worden ist. Lieferfristtage sind Arbeitstage.

3. In Fällen höherer Gewalt oder sonstiger von uns nicht zu vertretender Umstände (z. B. behördliche Maßnahmen, Streik, Aussperrung, Betriebsstörungen, Materialbeschaffungsprobleme, Verkehrsstörungen usw., - auch wenn sie beim Vorlieferanten eintreten) verlängern sich die - auch bestätigten - Lieferfristen in angemessenem Umfang. Das gilt auch dann, wenn die vorbezeichneten Umstände während eines bereits eingetretenen Verzugs entstehen. Wird uns aufgrund solcher Umstände die Leistung unmöglich oder unzumutbar, so werden wir von unserer Leistungspflicht frei. Sofern die Lieferverzögerung länger als einen Monat dauert, sind wir und der Besteller berechtigt, vom Vertrag zurückzutreten. Die Geltendmachung von Schadenersatzansprüchen ist ausgeschlossen.

6. Zahlungen

1. Zahlungen sind innerhalb von vierzehn Tagen nach Erhalt der Rechnung ohne Abzug zu leisten.

2. Ist die Erfüllung unseres Zahlungsanspruchs wegen nach Vertragsabschluss eingetretener oder bekannt gewordener schlechter Vermögensverhältnisse des Bestellers gefährdet, so steht uns das Recht zu, per Nachnahme zu liefern, Vorkasse zu verlangen, noch nicht ausgelieferte Ware zurückzubehalten sowie die Weiterarbeit an noch laufenden Aufträgen einzustellen und von bereits mit dem Besteller geschlossenen Verträgen zurückzutreten, sofern dieser nicht eine Vorauszahlung oder andere Sicherheit leistet. Sofern Wechselzahlung vereinbart wird, hat der Besteller sämtliche Wechsel- und Diskontspesen zu tragen.

7. Eigentumsvorbehalt

1. Die gelieferte Ware bleibt bis zur Erfüllung sämtlicher aus der Geschäftsverbindung bestehenden sowie künftig entstehenden Forderungen als Vorbehaltsware in unserem Eigentum. Das gilt auch dann, wenn einzelne oder sämtliche Forderungen in eine laufen-

de Rechnung aufgenommen wurden und der Saldo gezogen und anerkannt ist. Akzente, Wechsel und Schecks gelten erst nach ihrer unwiderruflichen Einlösung als Erfüllung.

2. Der Besteller ist nur dann berechtigt, die Waren im ordentlichen Geschäftsgang weiterzuveräußern, wenn er uns hiermit schon jetzt alle Forderungen abtritt, die ihm aus der Weiterveräußerung gegen Abnehmer oder Dritte erwachsen. Zu anderen Verfügungen über die Vorbehaltsware, insbesondere Verpfändung oder Sicherungsübereignung, ist der Besteller nicht berechtigt. Wird die Vorbehaltsware unverarbeitet oder nach Verarbeitung oder Verbindung mit Gegenständen, die ausschließlich im Eigentum des Bestellers stehen, veräußert, so tritt der Besteller schon jetzt die aus der Weiterveräußerung der Vorbehaltsware entstehenden Forderungen in voller Höhe an uns ab. Wird Vorbehaltsware vom Besteller - nach Verarbeitung/Verbindung - zusammen mit nicht uns gehörender Ware veräußert, so tritt der Besteller schon jetzt die aus der Weiterveräußerung entstehenden Forderungen in Höhe des Wertes der Vorbehaltsware mit allen Nebenrechten und Rang vor dem Rest ab. Wir nehmen die Abtretung an. Besteht zwischen dem Besteller und seinem Käufer ein Kontokorrentverhältnis, so erstreckt sich die Abtretung nicht nur auf den nach § 355 HGB anerkannten Saldo, sondern auch auf den etwaigen Überschuss aus dem Kontokorrentverhältnis, der ohne Feststellung und Anerkennung sofort zur Zahlung fällig ist. Zur Einziehung dieser Forderungen ist der Besteller auch nach Abtretung bis auf Widerruf ermächtigt. Unsere Befugnis, die Forderungen selbst einzuziehen, bleibt hiervon unberührt; jedoch verpflichten wir uns, die Forderungen nicht einzuziehen und die Einziehungsermächtigung des Bestellers nicht zu widerrufen, solange Letzterer seinen Zahlungs- und sonstigen Verpflichtungen ordnungsgemäß nachkommt. Wir können verlangen, dass der Besteller uns die abgetretenen Forderungen und deren Schuldner bekanntgibt, alle zum Einzug erforderlichen Angaben macht, die dazugehörigen Unterlagen aushändigt und den Schuldner die Abtretung mitteilt. Eine etwaige Be- oder Verarbeitung der Vorbehaltsware nimmt der Besteller für uns als Hersteller vor, ohne dass für uns daraus Verpflichtungen entstehen. Bei Verarbeitung, Verbindung, Vermischung oder Vermengung der Vorbehaltsware mit anderen, uns nicht gehörenden Waren steht uns der dabei entstehende Miteigentumsanteil an der neuen Sache im Verhältnis des Wertes der Vorbehaltsware zu der übrigen verarbeiteten Ware zum Zeitpunkt der Verarbeitung, Verbindung, Vermischung oder Vermengung zu. Erwirbt der Besteller das Alleineigentum an der neuen Sache, so besteht Einigkeit, dass der Besteller uns im Verhältnis des Wertes der verarbeiteten bzw. verbundenen, vermischten oder vermengten Vorbehaltsware Miteigentum an der neuen Sache einräumt und diese unentgeltlich für uns verwahrt.

3. Der Besteller verpflichtet sich, die von uns gelieferte Ware nur mit der Maßgabe zu veräußern, dass er sich das Eigentum an dieser

Ware bis zur vollständigen Kaufpreiszahlung vorbehalten und vereinbart, dass anstelle des Eigentumsvorbehalts, wenn dieser durch Weiterveräußerung, Verbindung, Verarbeitung oder Vermengung erlischt, das Eigentum an der neuen Sache oder die daraus entstehende Forderung tritt.

4. Im Falle des Zahlungsverzuges oder eines Antrages auf Eröffnung des Insolvenzverfahrens über das Vermögen des Bestellers sind wir berechtigt, die sofortige Herausgabe der Vorbehaltsware zu beanspruchen. In der Rücknahme liegt kein Rücktritt vom Vertrag. Gleichzeitig werden die befristeten Forderungen dann sofort zur Zahlung fällig. Hereingebene Wechsel sind unabhängig von Ihrer Fälligkeit Zug um Zug gegen Bargeldzahlung einzulösen.

5. Übersteigt der Wert der bestehenden Sicherheiten die zu sichernden Forderungen um mehr als 25 %, sind wir auf Verlangen des Bestellers insoweit zur Freigabe der Sicherheiten, die über den Wert von 125 % unserer Forderungen hinausgehen, verpflichtet. Die Auswahl der freizugebenden Sicherheiten steht uns zu.

6. Kommt der Besteller in Verzug oder stellt er die Zahlung ein, so sind wir berechtigt, uns an Ort und Stelle im Betrieb des Bestellers davon zu unterrichten, ob und in welchem Umfang Eigentumsvorbehaltsware vorhanden ist. Noch vorhandene Ware dürfen wir in Besitz nehmen, ohne dass es einer Zustimmung des Bestellers oder seines Verwalters bedarf.

7. Zugriffe Dritter auf Vorbehaltsware oder an deren Stelle getretene Forderungen sind uns vom Besteller unverzüglich unter Beifügung von Dokumenten mitzuteilen.

8. Gewährleistung und Haftung

1. Eventuelle Mängelrügen und Beanstandungen jeglicher Art haben unverzüglich nach Empfang der Lieferung zu erfolgen, § 377 HGB. Die beanstandeten Teile sind nach vorheriger Rücksprache frachtfrei an uns einzusenden.

2. Die regelmäßige Gewährleistungsfrist beträgt 12 Monate.

3. Bei vorhandenen Mängeln sind wir nach unserer Wahl zur Nachbesserung oder Ersatzlieferung berechtigt. Bei Ersatzlieferung tragen wir die Kosten für das Ersatzstück einschließlich des Versands zum vertraglich ursprünglich vereinbarten Lieferort, nicht jedoch für Aus- und Einbau oder sonstigen Aufwand. Erfolgt aufgrund eines Verlangens des Bestellers die Versendung an einen anderen Ort oder Leistungen von uns vor Ort, so übernimmt der Besteller die hierdurch anfallenden Mehrkosten. Ausgetauschte Gegenstände gehen in unser Eigentum über. Die Gewährleistungsfrist für das Ersatzstück läuft bis zum Ablauf der ursprünglichen Gewährleistungsfrist für den Liefergegenstand.

Ist eine Nachbesserung oder Ersatzlieferung unmöglich oder mindestens zweimal fehlgeschlagen oder von uns trotz angemessener Fristsetzung nicht erfolgt, so kann der Besteller Wandelung oder Minderung verlangen.

4. Für Mängel oder Schäden, die ohne unser Verschulden durch ungeeignete oder unsachgemäße Verwendung, fehlerhafte Montage

bzw. Inbetriebsetzung, übermäßige Beanspruchung, natürliche Abnutzung, fehlerhafte oder nachlässige Behandlung, ungeeignete Betriebsmittel, chemische, elektrochemische oder elektrische Einflüsse (soweit diese nicht vertraglich vorausgesetzt sind) entstanden sind, übernehmen wir keine Gewähr.

5. Der Ersatz von Schäden, die nicht am Liefergegenstand selbst entstanden sind (Mangelfolgeschaden) ist, soweit gesetzlich zulässig, ausgeschlossen. Wir haften nicht für Schäden, die nicht auf Vorsatz oder grobe Fahrlässigkeit zurückzuführen sind, es sei denn, das Verschulden betreffe eine Kardinalpflicht und/oder einen Inhaber oder leitenden Angestellten unseres Unternehmens.

6. Unsere Haftung ist auf den Netto-Warenwert der Lieferung begrenzt, aus der der mangelhafte Gegenstand stammt. Sie beschränkt sich auf den typischerweise vorhersehbaren Schaden.

9. Haftungsausschluss

1. Wir haften nicht für die Verfügbarkeit oder für die Aktualität, Richtigkeit und Vollständigkeit sowie für die Lieferfähigkeit der in unseren Katalog eingestellten Leistungen. Insbesondere enthält die Darstellung und Beschreibung einzelner Produkte keine abschließende Beschreibung der Beschaffenheit. Die Produktdarstellungen repräsentieren in der Regel einen Teil der betreffenden Produktfamilie. Innerhalb dieser Produktfamilien können einzelne Artikel variieren.

2. Als Beschaffenheit der Ware gilt grundsätzlich nur die Produktbeschreibung des Herstellers als vereinbart. Öffentliche Äußerungen, Anpreisungen oder Werbung des Herstellers stellen daneben keine vertragsgemäße Beschaffenheitsangabe der Ware dar.

10. Sonstiges

1. Erfüllungsort für Lieferung und Zahlung ist Böhmenkirch. Gerichtsstand für alle sich aus dem Vertragsverhältnis ergebenden Streitigkeiten - auch für Wechsel- und Scheckklagen - ist das für unseren Firmensitz sachlich und örtlich zuständige Gericht. Dasselbe gilt, wenn der Kunde keinen allgemeinen Gerichtsstand in Deutschland hat oder Wohnsitz oder gewöhnlicher Aufenthalt im Zeitpunkt der Klageerhebung nicht bekannt sind. Als maßgebliches Recht findet ausschließlich deutsches Recht unter Ausschluss des UN-Kaufrechts Anwendung.

2. Sollte eine Bestimmung dieser Bedingungen unwirksam sein, so bleibt die Wirksamkeit der übrigen Bestimmungen hiervon unberührt. Die unwirksame Bestimmung wird durch eine solche ersetzt, mit der der ursprünglich erstrebte wirtschaftliche Zweck bestmöglich erreicht wird.

Stand Januar 2005

General terms and conditions of sale and delivery of Keck & Lang GmbH

1. General information, applicability

1. Only commercial customers are invited to place orders. By placing an order, Orderer confirms that all legal business concluded with us shall be attributed to its commercial or free-lance professional occupation.

2. We shall perform our deliveries and services exclusively on the basis of the following General Terms and Conditions of Business. We shall not agree to any divergent terms or conditions of the contracting party.

3. It shall be agreed that these General Terms and Conditions of Business also apply to further contracts without this requiring express mention hereafter.

4. Divergent or supplementary agreements shall only be effective if they have been concluded in writing or confirmed by us in writing.

2. Accomplishment of the agreement

1. All services presented in our catalogue represent no more than a request to Orderer to make an offer. We reserve the right to accept such an offer. An agreement shall not be accomplished until we have confirmed such. The confirmation can be made by letter, fax, e-mail or conclusively through the fulfilment of the order.

3. Prices

1. Statutory VAT must be added to our prices. They apply ex works and therefore exclude expenses for freight, postage and insurance, as well as any other shipping costs. We deliver franco domicile for goods exceeding a minimum value which we shall state to you upon request.

4. Deliveries, transfer of risk

1. Partial deliveries are permissible and obligate Orderer to pay the partial remuneration unless the acceptance of the partial delivery would be unreasonable. Each partial delivery shall be considered to fulfil a separate order within the scope of these Terms and Conditions.

2. Goods shall be delivered ex works at Orderer's expense. The risk attached to the goods shall be transferred to Orderer when the goods leave the ramp at the manufacturer's plant or when manufacturer notifies readiness for shipment. This shall also apply to partial deliveries and in the event that we have assumed

forwarding expenses or carriage of the goods.

3. The goods shall be delivered in a dismantled condition insofar as the type of shipment and transportation risk so require.

4. A transportation or other insurance policy shall only be taken out at the express request and at the expense of Orderer.

5. In the event that acceptance is delayed, Orderer shall bear the storage costs we thereby incur. These shall amount to half a percent for each full week of delay, but a maximum total of 5 % of the net value of the goods not accepted. Orderer shall retain the right to prove that lesser damages were incurred, as we shall be entitled to prove higher damages. We shall be entitled to dispose otherwise of the delivery item upon expiration of a reasonable time period set by ourselves and to supply Orderer within reasonably extended delivery periods.

5. Delivery periods and deadlines

1. The delivery periods we indicate are subject to change without notice and merely approximate unless firm deals are expressly arranged in specific agreements. They shall not be applicable until we have received from our customers all documents, permits and clearances necessary for the fulfilment of the order and when agreed payments have been received in due time.

2. The delivery period shall begin at the earliest when Orderer receives our order confirmation. The deadline shall be considered to have been met when the delivery items leave the ramp at the manufacturer's plant within the set period or readiness for delivery has been announced. Delivery periods shall be counted in working days.

3. In cases of force majeure or other circumstances beyond our control (such as actions of the authorities, strike, lockout, interruption of operations, material sourcing problems, traffic jams, etc. – even if they occur at a supplier of vendor), the delivery periods, including confirmed periods, shall be extended by a reasonable amount of time. This shall also apply when the above-mentioned circumstances arise during a delay which has already occurred. If performance should become impossible or unreasonable for us under such circumstances, then we shall be exempted from our duty to perform. Insofar as the delay in delivery should last for more than one month, we and Orderer shall be entitled to withdraw from the agreement. Claims for compensation of damages shall be excluded.

6. Payments

1. Payments must be made without deduction within fourteen days of receipt of the invoice.

2. If the fulfilment of our claim to payment should be endangered owing to poor pecuniary circumstances on the part of Orderer which were unknown or not existent at the time the agreement was concluded, then we shall be entitled to delivery COD, to demand payment in advance, to retain goods not yet delivered, or to cease work on pending orders and withdraw from agreements already concluded with Orderer, insofar as the latter does not pay in advance or put up other security. Insofar as payment by bill of exchange has been agreed, Orderer must bear all expenses and discount charges related to the bill of exchange.

7. Retention of title

1. The delivered goods shall remain in our possession as goods subject to retention of title until all present and future demands pursuant to the business relationship have been fulfilled. This shall also apply if specific demands or all demands were included in a current account and the balance has been struck and accepted. Bills of acceptance, bills of exchange and cheques shall not be considered valid fulfilment until they have been irrevocably cashed.

2. Orderer shall only be entitled to resell the goods in a proper business if Orderer hereby assigns to us all receivables from buyers or third parties which should accrue to Orderer from such resale. Orderer shall have no right

to dispose otherwise of the goods subject to retention of title, in particular, pledging or chattel mortgage. Should the goods subject to retention of title be sold unprocessed or after processing or in combination with items which are exclusively in the possession of Orderer, then Orderer shall here and now assign to us in full all claims to said goods arising from their resale. If goods subject to retention of title are sold together with goods not belonging to us – after being processed/combined – then Orderer shall here and now transfer to us all claims to said goods in the amount of their value, along with all ancillary rights and ranking before other rights.

We shall accept the transfer.

If Orderer should have a current account relationship with the purchaser, then the transfer shall cover not only the balance recognized pursuant to § 355 of the German Commercial Code, but also any surplus from the current account relationship, which shall be due for payment immediately without statement and acknowledgement. Orderer shall also be authorized to collect these claims after the transfer until this right is cancelled. This shall not affect our right to collect the claims. However, we shall undertake not to collect the claims and not to cancel Orderer's authorization to collect the claims for as long as the latter duly meets its obligations to make payment and other obligations. We can demand that Orderer disclose to us the transferred claims and their debtors, provide all data necessary for collection, hand over the appurtenant documents and notify the debtors of the transfer. Orderer shall undertake for us as manufacturer any processing or treatment of the goods subject to retention of title without this putting any obligation on ourselves. In the event that the goods subject to retention of title should be processed, combined, mixed or commingled with any other goods not belonging to us, we shall be entitled to a co-ownership share in the new item in proportion to the value of the goods subject to retention of title in relation to the other processed goods at the time they are processed, combined, mixed or commingled. Should Orderer acquire sole ownership to the new item, then it is agreed that Orderer shall grant us co-ownership in proportion to the value of the processed or combined, mixed or commingled goods subject to retention of title in the new item and shall hold such in safe custody for us free of charge.

3. Orderer shall undertake only to sell the goods we deliver under the condition that Orderer retains ownership of these goods until the full purchase price is paid, and shall agree that ownership of the new item or the claim arising therefrom shall take the place of the retention of title if such should expire as a consequence of resale, combination, processing or mixing.

4. In the event that Orderer should default in payment or file a petition in bankruptcy, we shall be entitled to demand that the goods subject to retention of title be handed over immediately. Taking these goods back shall not constitute a withdrawal from the contract. At the same time, term claims shall then become due for payment immediately. Bills of

exchange submitted must be redeemed irrespective of their due date in return for cash payment under concurrent conditions.

5. Should the value of the existing securities exceed by more than 25 % the value of the claims to be safeguarded, then we shall be obligated, at Orderer's request, to release the securities which exceed the value of our claims by more than 125 %. We shall be entitled to choose the securities to be released.

6. Should Orderer default or cease payment, then we shall be entitled to inform ourselves on Orderer's premises whether and to what extent goods subject to retention of title are present. We shall be entitled to take possession of goods still on hand without requiring the consent of Orderer or its administrator.

7. Orderer must notify us immediately, enclosing documents, of access of third parties to the goods subject to retention of title or claims arising in their place.

8. Warranty and liability

1. Any notice of defects or complaints of any kind at all must be made immediately following receipt of the delivery, § 377 of the German Commercial Code. The faulty parts must be sent to us, carriage free, following prior consultation.

2. The regular warranty period amounts to twelve months.

3. In the event of faults, we shall be entitled to rework or provide replacement, as we choose. Should we provide replacement, we shall bear the cost of sending the replacement piece to the originally agreed destination, but we shall not assume any expenses for dismantling or installation. Should Orderer demand that the replacement be sent to another place, or that we perform services on site, then Orderer shall assume the extra costs. Exchanged items shall come into our possession. The warranty period for the replacement shall run until the original warranty period for the delivered item expires.

If it is not possible to rework or replace the faulty item, or if such has failed at least twice, or if we have not accomplished this despite the setting of an appropriate deadline, then Orderer shall be entitled to demand revision or reduction.

4. We shall grant no warranty for defects or damages for which we are not responsible or which are due to improper use, faulty assembly or start-up, excessive strain, natural wear and tear, faulty or negligent handling, unsuitable production equipment and facilities, or chemical, electrochemical or electrical influences (insofar as these were not provided for by contract).

5. Compensation for damages which are not suffered by the delivery item itself (consequential harm caused by a defect) shall be excluded insofar as legally permissible. We shall assume no liability for damages which are not due to premeditation or gross negligence unless the blame should attach to a cardinal obligation and/or an owner or executive staff member of our company.

6. Our liability shall be limited to the net value of the goods delivered from which the faulty

item comes. It shall be limited to typically foreseeable damage.

9. Exemption from liability

1. We do not guarantee that the services in our catalogue are available, up to date, correct, complete or capable of delivery. In particular, the representation and description of individual products does not constitute an exhaustive description of their properties. The product depictions represent as a rule a part of the product family involved. Specific articles within these product families may vary.

2. Only the product description of the manufacturer shall be considered to describe a quality of the goods. Public statements, advertising or other expressions of the manufacturer extolling the goods shall not constitute a contractual indication of their qualities.

10. Miscellaneous

1. The place of fulfilment for delivery and payment shall be Böhmenkirch. The legal venue for any disputes arising from this contractual relationship shall rest with the competent court for such matters in the city in which our registered office is located. The same shall apply if Customer has not general legal venue in Germany,

or if the residence or usual place of abode or is not known at the time the suit is filed. German law shall be exclusively applicable, also excluding the application of the United Nations convention on contracts for the international sale of goods.

2. Should a provision of these Terms and Conditions be ineffective, this shall not affect the legal force of the remaining provisions. The ineffective provision shall be replaced by one which best approximates the commercial intent and purpose of the original provision.

Dated: January 2005

Conditions générales de vente de la société Keck & Lang GmbH

1. Généralités et champ d'application

1. Seuls des clients professionnels ont la possibilité de passer des commandes. Par le biais de sa commande, le client confirme qu'il agit, lors de la conclusion de l'acte juridique, dans l'exercice de son activité professionnelle commerciale ou indépendante.

2. Nous proposons nos prestations et la livraison de produits uniquement aux conditions générales de vente ci-après définies. Toutes conditions divergentes émanant du cocontractant sont expressément exclues par les présentes conditions.

3. Il a été convenu que les présentes conditions générales de vente valent également pour les ordres ultérieurs sans qu'il y soit à nouveau expressément fait référence.

4. Toutes conventions contraires ou annexes requièrent la forme écrite ou une confirmation de notre part pour être valables.

2. Conclusion du contrat

1. Toutes les prestations décrites dans notre catalogue constituent uniquement une invitation à l'offre, adressée au client, à passer commande. Nous nous réservons le droit de refuser une commande. Toute conclusion de contrat est soumise à confirmation de notre part. Cette confirmation peut s'effectuer par courrier, fax, e-mail ou de façon concluante par l'exécution de la commande.

3. Prix

1. Nos prix sont majorés du taux de TVA légale en vigueur. Ils s'entendent « départ usine » et excluent par conséquent le prix du fret, les frais de port et d'assurance ainsi que d'autres frais de transport. A partir d'une valeur de marchandise minimum, que nous vous indiquerons sur demande, nous sommes disposés à livrer franco domicile.

4. Livraisons et transfert des risques

1. Les livraisons partielles sont admises et font l'objet de facturations séparées, sauf si ce type de livraison n'est pas envisageable. Chaque livraison partielle est à considérer comme exécution d'un ordre particulier au sens des présentes conditions.

2. Les livraisons interviennent « départ usine » et sont à la charge du client. Le transfert des risques au client s'opère au moment où la marchandise quitte la rampe de chargement de l'usine de fabrication ou au moment de la communication de la mise à disposition pour expédition. Ceci vaut également en cas de livraison partielle et en cas de prise en charge par notre société des frais de livraison ou du transport de la marchandise par nos propres véhicules.

3. La marchandise est livrée démontée si le mode d'expédition ou les risques de transport l'exigent.

4. La souscription d'une assurance de transport ou autre, est uniquement effectuée sur demande expresse et aux frais du client.

5. En cas de retard d'acceptation, les frais de stockage ainsi engendrés sont à la charge du client. Ces frais s'élèvent à %, sans toutefois dépasser 5%, du montant net de la marchan-

dise non retirée, pour chaque semaine de retard pleine. Le client conserve le droit de prouver que le dommage est moindre et notre société conserve le droit de prouver que ce dommage est supérieur. Après écoulement d'un délai raisonnable fixé par notre société, nous nous réservons le droit de disposer autrement de l'objet de la livraison et de livrer le client dans des délais supplémentaires convenables.

5. Délais et dates de livraison

1. Les délais de livraison fixés par notre société sont sans engagement de notre part et n'ont qu'une valeur indicative sauf si une date de livraison particulière a été expressément convenue par convention particulière. Ceci est uniquement déterminant si le client nous a transmis, à temps, l'ensemble des documents, autorisations, validations nécessaires à l'exécution de l'ordre ainsi que le paiement des sommes convenues.

2. Le délai de livraison commence à courir au plus tôt à réception de notre confirmation de commande par le client. Il est considéré comme étant respecté si l'objet de la livraison a quitté la rampe de chargement de l'usine de fabrication dans les délais convenus ou si la mise à disposition pour expédition a été communiquée. Le délai de livraison se décompte uniquement par jours ouvrés.

3. Les cas de force majeure ou autres événements imprévisibles dont nous ne sommes pas responsables (par exemple fait du prince, grèves, lock-out, perturbation de la production, problèmes d'approvisionnement en matériel, problèmes de circulation routière etc. – même si le fournisseur rencontre ces difficultés) nous autorisent à proroger en conséquence les délais de livraison – même confirmés. Il en va de même si les événements susmentionnés surviennent en cas de retard déjà existant. Si pour les raisons susmentionnées, la livraison devait être inacceptable voire impossible, nous serions en droit de nous décharger de nos obligations. En cas de retard de livraison supérieur à un mois, chacune des deux parties serait en droit de résilier le contrat. Toute action en dommages et intérêts est exclue.

6. Paiements

1. Les paiements sont à effectuer dans les 15 jours suivant la réception de la facture, sans que cela n'entraîne aucune réduction particulière.

2. Si le paiement de nos prestations, après conclusion du contrat, devait être menacé par des difficultés de liquidités chez notre client, nous nous réservons le droit de livrer la marchandise contre remboursement, de demander un paiement anticipé, de conserver la marchandise n'ayant pas encore été livrée ainsi que de stopper les travaux liés aux commandes en cours et de résilier les contrats déjà conclus avec le client, dans la mesure où tout versement d'acompte ou constitution de sûretés s'avèrent impossible. En cas de paiement par lettre de change, l'ensemble des frais de change et d'escompte sont à la charge du client.

7. Clause de réserve de propriété

1. Nous nous réservons la propriété de la marchandise livrée jusqu'à réception de l'intégralité des paiements résultant de la relation d'affaires avec le client. Ceci vaut également si une ou l'ensemble des créances ont été intégrées à un compte courant et que le solde déterminé a déjà été reconnu. Les traites acceptées, lettres de change et chèques sont considérés comme étant libératoires de tout paiement une fois qu'ils ont été irrévocablement encaissés.

2. Le client a le droit de revendre la marchandise grevée par la réserve de propriété dans le cadre de ses activités commerciales habituelles, à condition de céder d'ores et déjà à notre profit l'ensemble des créances détenues à l'égard de son acheteur ou des tiers résultant de la revente de la marchandise. Toute autre utilisation de la marchandise grevée par la réserve de propriété, telle que la constitution de gage ou cession de la marchandise à titre de garantie par le client, est interdite. Si la marchandise grevée par la réserve de propriété est vendue non transformée, ou après transformation ou incorporation à d'autres biens dont le client est seul propriétaire, le client nous cède par anticipation les créances résultant de la revente de la marchandise grevée par la réserve de propriété et ce, à concurrence de leur montant intégral. Si la marchandise grevée par la réserve de propriété est vendue par le client – suite à transformation / incorporation – avec d'autres objets dont nous n'avons pas la propriété, le client nous cède par anticipation les créances résultant de la revente à hauteur de la valeur de la marchandise grevée par la réserve de propriété, ainsi que tous les droits accessoires à la marchandise et ce, de manière prioritaire. Nous acceptons d'ores et déjà cette cession. Si le client possède un compte courant dans le cadre de sa relation d'affaires avec son acheteur, la cession s'étend non seulement au solde reconnu selon § 355 HGB (Code de commerce allemand) mais également de l'excédent étant immédiatement exigible sans fixation ni reconnaissance. Le recouvrement de ces créances cédées est effectué par le client sauf révocation de cette faculté de notre part. Cette disposition n'affecte en rien notre droit de procéder nous-mêmes au recouvrement des créances.

Nous nous engageons toutefois à ne pas procéder au recouvrement des créances et à ne pas révoquer l'autorisation de recouvrement accordée au client, tant que ce dernier s'acquitte régulièrement de son obligation de paiement et autres. En revanche, nous sommes en droit d'exiger du client qu'il nous communique l'ensemble des éléments relatifs aux créances cédées et à leurs débiteurs ainsi que l'ensemble des informations nécessaires au recouvrement, qu'il nous transmette les documents relatifs aux créances faisant l'objet de la cession et qu'il informe les débiteurs de cette cession.

Le traitement ou la transformation de la marchandise grevée par la réserve de propriété est effectué par le client pour le compte de notre société en sa qualité de fabricant, sans

que cela n'engendre quelconque obligation de notre part. En cas de transformation, association, incorporation ou mélange de la marchandise grevée par la réserve de propriété à d'autres marchandises dont nous n'avons pas la propriété, nous acquérons la propriété de la chose ainsi créée au prorata de la valeur de la marchandise grevée par la réserve de propriété par rapport à la valeur des autres biens traités au moment de la transformation, association, incorporation ou mélange. Si le client acquiert la propriété exclusive de la nouvelle chose ainsi créée, le client nous cède la copropriété de cette chose au prorata de la valeur de la marchandise grevée par la réserve de propriété transformée ou associée, incorporée ou mélangée et en assure la garde pour notre compte à titre gratuit.

3. Le client s'engage à ne revendre la marchandise livrée par nos soins qu'à condition de se réserver le droit de propriété de cette marchandise jusqu'au paiement de l'intégralité du prix de vente et s'engage, en lieu et place de cette réserve de propriété, lorsque celle-ci disparaît suite à une revente, transformation, association, incorporation, ou mélange, à nous transmettre la propriété sur la chose transformée ou à nous céder les créances en résultant.

4. En cas de retard de paiement ou d'ouverture d'une procédure collective à l'encontre du client, nous sommes en droit d'exiger la restitution immédiate de la marchandise grevée par la réserve de propriété. Une telle reprise par nos soins n'est pas constitutive d'une résiliation du contrat. En revanche, les créances à terme sont immédiatement exigibles. Nonobstant leur exigibilité, les lettres de change obtenues sont

à encaisser contre paiement comptant.

5. Dans la mesure où la valeur de réalisation de nos sûretés dépasse de plus de 25% la valeur des créances à garantir, nous nous engageons, à la demande du client, à consentir la mainlevée des sûretés dont nous bénéficions et dont le montant dépasse une valeur de 125% de nos créances. Il est précisé que le choix des sûretés dont la mainlevée peut être accordée nous appartient.

6. Si le client accuse un retard ou une cessation de paiement, nous sommes en droit de nous rendre sur place, dans les locaux du client, afin de constater si des marchandises grevées par la réserve de propriété sont encore disponibles et en quelle quantité. Nous sommes en droit de reprendre la marchandise encore disponible et ce, nonobstant l'accord du client ou de son administrateur.

7. Le client s'engage à nous informer immédiatement, en joignant les documents correspondant, de toute saisie de tiers de marchandises grevées par la réserve de propriété ou créances cédées à cet effet.

8. Garantie et responsabilité

1. Toutes plaintes et réclamations éventuelles sont à communiquer immédiatement à réception de la livraison, § 377 HGB (Code de commerce allemand). Les pièces faisant l'objet d'une réclamation sont à nous retourner fran-

co de port après concertation.

2. Le délai de garantie normal est de 12 mois.

3. En cas de vices, nous procéderions soit à la réparation, soit au remplacement de la marchandise, étant précisé que le choix de l'une ou de l'autre mesure nous appartient.

En cas de réparation, nous prenons en charge le coût de la pièce de rechange ainsi que les frais de transport au lieu contractuel initialement convenu, à l'exception des démontages et montages ou autres dépenses. Si la marchandise est livrée, sur demande du client, à un autre endroit ou en cas de prestations effectuées sur place par nos soins, les frais supplémentaires ainsi engendrés sont à la charge du client. Nous acquérons la propriété des objets échangés. Le délai de garantie de la pièce de rechange court jusqu'à l'expiration du délai de garantie initial de l'objet de la livraison. Si une réparation ou une livraison de remplacement devait s'avérer être impossible ou a au moins échoué par deux fois déjà ou ne peut être effectuée par nos soins malgré la fixation d'un délai raisonnable, le client est en droit d'exiger la résolution de la vente ou une réduction.

4. Toute garantie est exclue en cas de vices ou dommages dont nous ne sommes pas responsables, liés à une utilisation inappropriée ou incorrecte, erreur de montage ou de mise en service, sollicitation excessive, usure normale, manipulation erronée ou négligée, matériaux inappropriés, influences chimiques, électrochimiques ou électriques (dans la mesure où elles ne sont pas stipulées au contrat).

5. Tout dédommagement en cas de vices n'ayant pas de lien direct avec l'objet de la livraison (dommages par ricochet provoqué par le vice de la chose)

est exclu dans les limites prévues par la loi. Nous ne pouvons être tenus pour responsables de dommages n'étant pas dus à une faute intentionnelle ou de négligence grave sauf si la faute est liée à une obligation essentielle au contrat et/ou un propriétaire ou cadre de notre société.

6. Notre responsabilité se limite à la valeur nette de la marchandise livrée et de laquelle provient l'objet défectueux. Elle se limite aux dommages typiques prévisibles.

9. Exclusion de responsabilité

1. Nous déclinons toute responsabilité quant à la disponibilité ou l'actualité, l'exactitude et l'exhaustivité et la capacité de livraison des prestations mentionnées dans notre catalogue. La présentation des différents produits ne peut en aucun cas être considérée comme une description définitive et immuable des caractéristiques de nos produits. Les caractéristiques des produits se rapportent en règle générale à une partie du groupe de produits concerné. Des articles appartenant au même groupe de produits peuvent se différencier.

2. Seule la description du produit provenant du fabricant vaut comme convention de qualité de la marchandise. Toute déclaration publique, préconisations ou publicité du fabricant ne peuvent être considérées comme indication de qualité de la marchandise conforme au contrat.

10. Dispositions finales

1. Le lieu d'exécution des obligations de livraison et de paiement est Böhmenkirch. Pour tous litiges nés de la relation contractuelle – également pour les actions cambiaires et actions en paiement de chèques -, seuls les tribunaux du siège de notre société sont compétents (compétence d'attribution et territoriale). Il en va de même si le client ne dispose pas de tribunal compétent en Allemagne ou si son domicile ou le lieu de séjour habituel est inconnu au moment de l'introduction d'instance. Seul le droit allemand, à l'exception des dispositions communautaires légales relatives à la vente, est applicable.

2. Si l'une des présentes conditions générales de vente était frappée de nullité, la validité de toutes les autres clauses ne s'en trouverait pas affectée. La clause nulle sera remplacée par une disposition valable correspondant au mieux à l'objectif économique de la clause inefficace.

Mise à jour janvier 2005